

Installation Notes:

- To install the rear wheel, reverse the removal procedure.
- Make sure that the slot (5) on the brake caliper is located in the lug (6) in the swingarm (7).
- Tighten the axle nut to:
93 N·m (9.5 kgf·m , 69 lbf·ft)
- Adjust the drive chain (page 97).
- Apply the brake several times and check for free wheel rotation after the brake pedal is released.
- Brake system inspection (page 116).

When installing the wheel, carefully fit the brake disc between the brake pads to avoid damaging the pads.

After installation, operate the brake pedal and check the brake operation.

If a torque wrench was not used for installation, see your Honda dealer as soon as possible to verify proper assembly. Improper assembly may lead to loss of braking capacity.

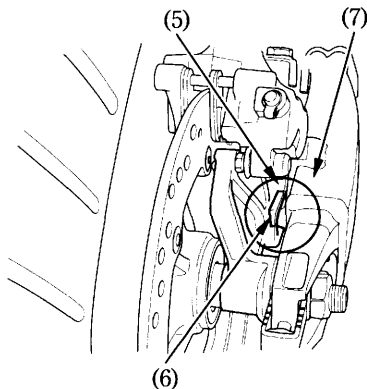

- (5) Slot
- (6) Lug

(7) Swingarm