

MAINTENANCE LID/LOWER FAIRING

Maintenance Lid

1. To remove the maintenance lid (1), remove two screws (2).
2. Hold the lid and push up so the lower tab (3) lifts out of the slot in the lower fairing.
3. Slowly pull the rear end of the lid out about 45° and remove the two side tabs (4) from their slots.

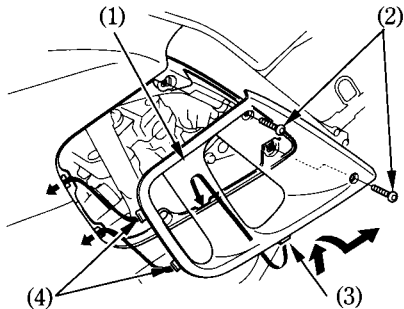

- | | |
|---------------------|---------------|
| (1) Maintenance lid | (3) Lower tab |
| (2) Screws | (4) Side tabs |

Lower Fairing

1. Remove the maintenance lid.
2. Pull the clips (5) out to the first detent position.
3. Remove the quick-release screw (6) and screw (7).
4. Remove the short mount screws (8) and long mount screw (9) by holding the lower fairing (10).
5. Remove the lower fairing by releasing the tabs (11).