

Rear Suspension Adjustments

The rear suspension can be adjusted for the rider's weight and riding conditions by changing the spring pre-load and the rebound and compression damping.

The rear shock absorber assembly includes a damper unit that contains high pressure nitrogen gas. Do not attempt to disassemble, service, or dispose of the damper; see your Honda dealer. The instructions found in this owner's manual are limited to adjustments of the shock assembly only.

Puncture or exposure to flame may also result in an explosion, causing serious injury. Service or disposal should only be done by your authorized Honda dealer or a qualified mechanic, equipped with the proper tools, safety equipment and the Honda Service Manual.

If your CRF is new, put enough part-throttle break-in time (about one hour) on it to ensure that the suspension has worked in.

Rear Suspension Spring Pre-Load

Pre-load should be adjusted when the engine is cold because it is necessary to remove the muffler (page 62).

An optional pin spanner is available for turning the lock nut and adjusting nut to adjust spring pre-load.

1. Place your CRF on an optional workstand or equivalent support with the rear wheel off the ground.
2. Loosen the connecting tube clamp screw and subframe mounting upper bolt, and remove the rear subframe mounting lower bolts, then lift the subframe. See page 39.

3. Check that the spring pre-load is adjusted to the standard length. Adjust as necessary by loosening the lock nut (1) and turning the adjusting nut (2).
Each complete turn of the adjusting nut changes the spring length by 0.06 in (1.5 mm).
4. After adjustment, hold the adjusting nut and tighten the lock nut to the specified torque: 32 lbf·ft (44 N·m, 4.5 kgf·m)

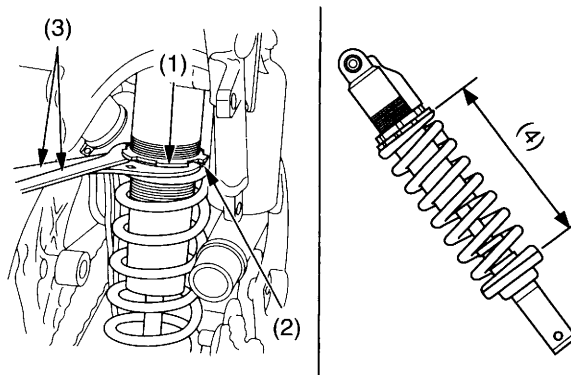

- (1) lock nut (3) pin spanners
(2) adjusting nut (4) spring length

To increase spring pre-load:

Loosen the lock nut with the optional pin spanner (3) and turn the adjusting nut to shorten the spring length (4). Do not shorten to less than: 9.6 in (243 mm)

To decrease spring pre-load:

Loosen the lock nut with the optional pin spanner (3) and turn the adjusting nut to increase the spring length (4). Do not increase to more than: 10.14 in (257.6 mm)

Each turn of the adjuster changes spring length and spring pre-load. One turn equals: spring length/spring pre-load:
0.06 in (1.5 mm) / 15.9 lbs (7.2 kg)

Pin spanners should be used for turning the lock nut and adjusting nut. See page 163 for optional pin spanners.

Spring pre-load length (Standard spring)
Standard: 10.10 in (256.6 mm)
Min. : 9.6 in (243 mm)

Spring pre-load length (Optional spring)
Min. (Softer, 4.55 kgf/mm): 9.7 in (246 mm)
Min. (Stiffer, 5.00 kgf/mm): 9.7 in (246 mm)
Min. (Stiffer, 5.20 kgf/mm): 9.8 in (248 mm)