

Valve Clearance

Crankshaft Hole Cap Installation

Coat a new O-ring (1) with engine oil and install it onto the crankshaft hole cap (2).

Apply grease to the crankshaft hole cap threads. Install and tighten the crankshaft hole cap to the specified torque:

11 lbf-ft (15 N-m, 1.5 kgf-m)

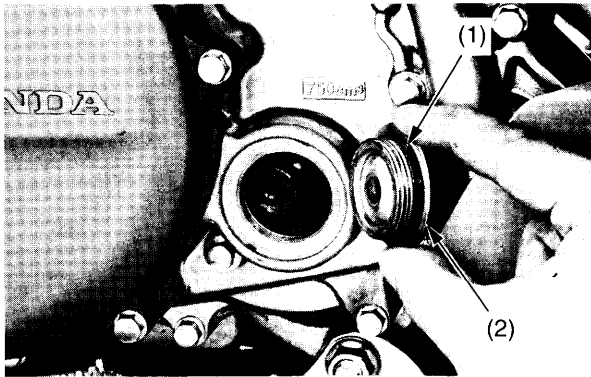

(1) O-ring
(2) crankshaft hole cap

Cylinder Head Cover Installation

1. Check the spark plug hole packing (1) is in good condition, replace it if necessary. Apply engine oil to the spark plug hole packing and install it to the spark plug hole (2).

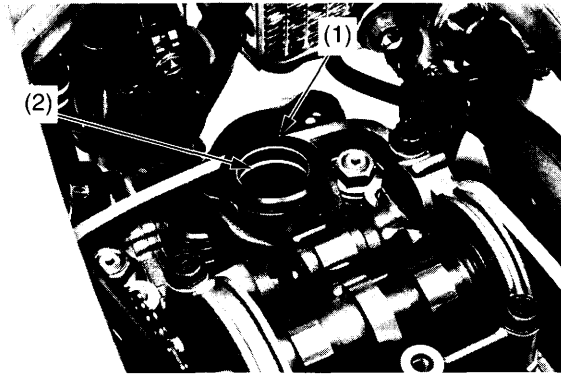

(1) spark plug hole packing
(2) spark plug hole

2. Inspect the cylinder head cover packing (3) for damage or deterioration, replace it if necessary. Install the cylinder head cover packing into the groove of the cylinder head cover (4).

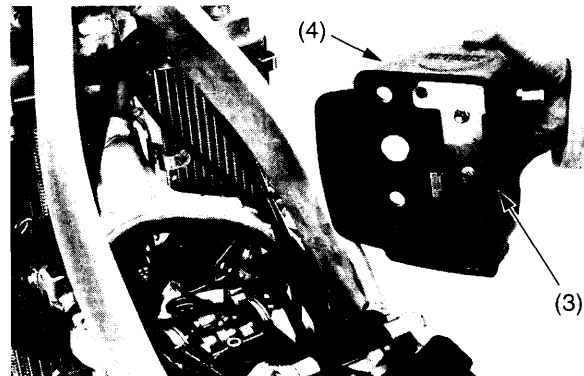

(3) cylinder head cover packing
(4) cylinder head cover

3. Check the rubber seals (5) are in good condition, replace them if necessary. Install the rubber seals onto the cylinder head cover with the "UP" marks (6) facing up.

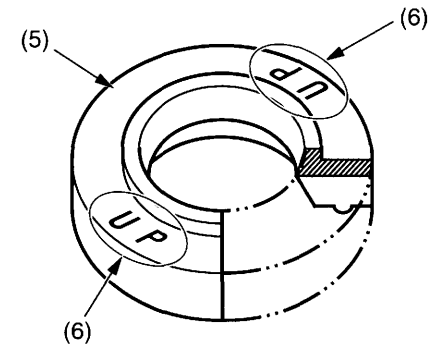

(5) rubber seal
(6) "UP" marks

4. Install the cylinder head cover (4).
5. Tighten the cylinder head cover A bolt/rubber seal (7) and cylinder head cover B bolts/rubber seals (8) to the specified torque: 7 lbf-ft (10 N-m, 1.0 kgf-m)

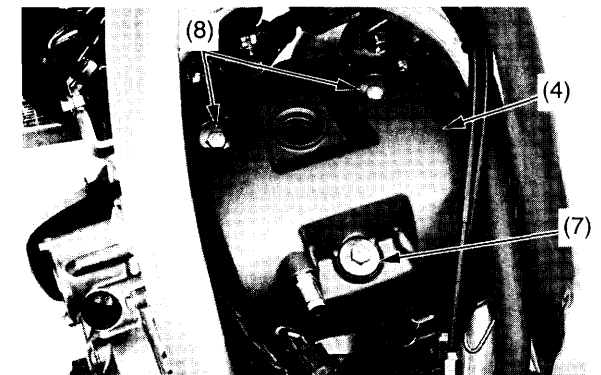

(4) cylinder head cover
(7) cylinder head cover A bolt/rubber seal
(8) cylinder head cover B bolts/rubber seals