



# Spark Plug

## Spark Plug Inspection & Replacement

Refer to *Safety Precautions* on page 147.

1. Remove the seat (page 158).
2. Loosen the screw (1) and remove the clip (2).
3. Remove the resonance chamber (3).
4. Unhook the rubber cover (4).
5. Clean any dirt from around the spark plug base.
6. Disconnect the spark plug cap (5). Take care to avoid damaging the spark plug wire when disconnecting the cap.
7. Using a spark plug wrench provided in the tool kit, remove the spark plug.
8. Inspect the electrodes and center porcelain for deposits, corrosion, or carbon fouling. If the corrosion or deposits are heavy, replace the plug.
9. Make sure that a 1.0 mm wire-type feeler gauge cannot be inserted between the spark plug gap (6). If the gauge fits in the gap, replace the plug with a new one.



### UNDER SEAT

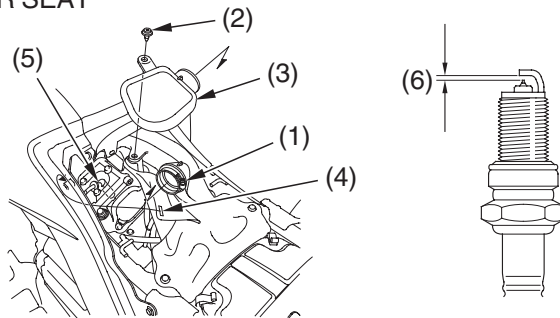

- |                       |                    |
|-----------------------|--------------------|
| (1) screw             | (4) rubber cover   |
| (2) clip              | (5) spark plug cap |
| (3) resonance chamber | (6) spark plug gap |

## 190 Servicing Your Honda

