

(1) DOWEL PINS
(2) NEW GASKET

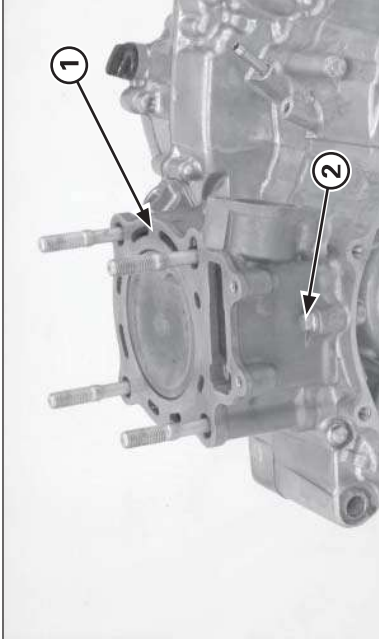

(1) CYLINDER
(2) NEW SEALING BOLT/SEALING WASHER

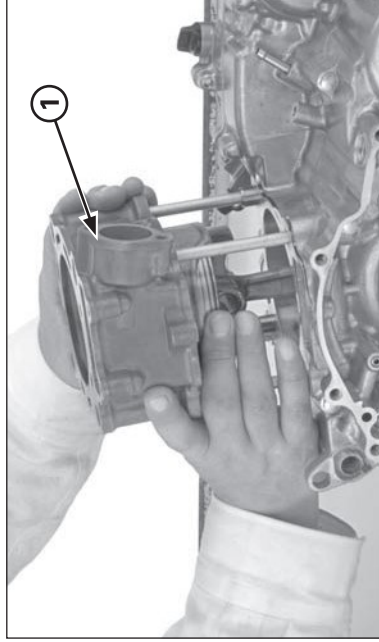

(1) CYLINDER

Cylinder Installation

Install the dowel pins and new gasket.

Coat the cylinder bore, piston and piston rings with clean engine oil and install the cylinder while compressing the piston rings being careful not to damage the rings.

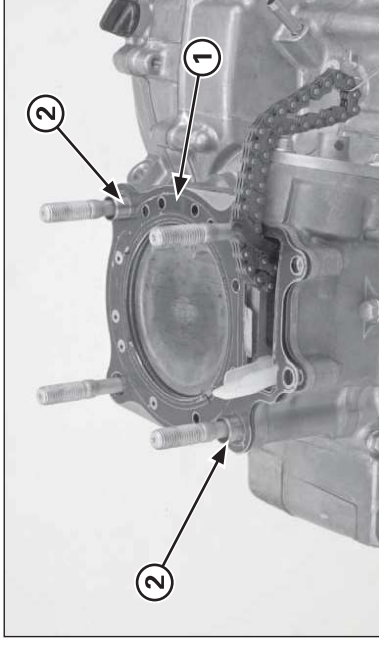

(1) DOWEL PINS
(2) NEW GASKET

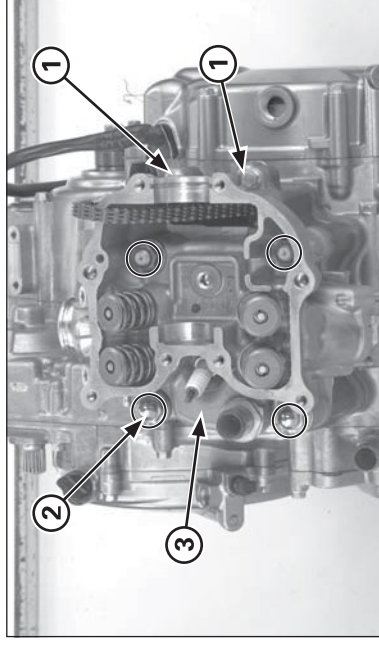

(1) CYLINDER HEAD
(2) WASHERS/NUTS
(3) BOLTS

Cylinder Head Installation

Install the dowel pins and new gasket.
Install the cylinder head onto the cylinder.
Apply oil to the cylinder head mounting nut threads and seating surface, install them with washers.
Install the two cylinder head 6 mm bolts.
Tighten the cylinder head nuts (cap nuts on right side) in a crisscross pattern in 2 – 3 steps to the specified torque.

Torque: 39 N·m (4.0 kgf·m, 29 lbf·ft)