

3. Changing from "Trip 1" to "Trip 2" display

1. With the motorcycle running and set to "Trip 1":
 - Press the M (Mode) button and the display will change to "Trip 2".
2. Press the S (Set) button.
 - Keep it pressed for several seconds and "Trip 2" will change to 0.0 km/h / mph.

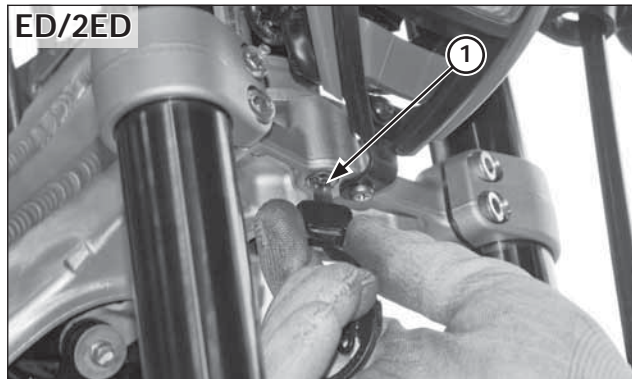

(1) STEERING LOCK

Steering lock (ED/2ED)

The steering lock is on the steering stem. To lock the steering, turn the handlebar all the way to the left, insert the steering key into the lock, turn the key counterclockwise as far as possible. Then, press the lock all the way in, turn the key back to the original position, and remove the key. To unlock the steering, perform the locking sequence in the reverse order.

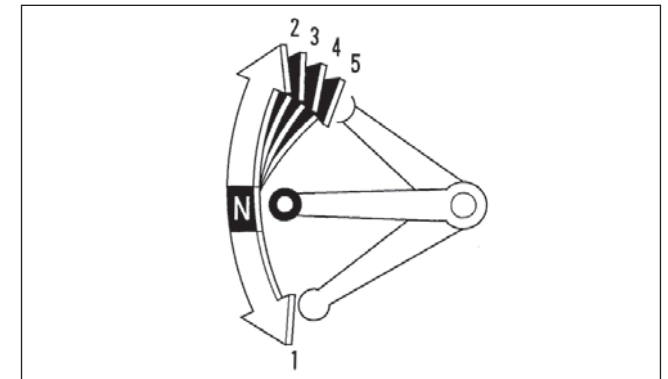

Shifting gears

Your Cota has five forward gears in a one-down, four-up shift pattern. To start riding, after the engine has been warmed and the side stand raised.

1. Close the throttle and pull the front brake lever in.
2. Pull the clutch lever all the way in.
3. Depress the shift lever from neutral down to first gear.
4. Release the front brake lever. Gradually open the throttle while you slowly release the clutch lever. If the engine min-1 (rpm) (speed) is too low when you release the clutch lever, the engine will stall. If the engine min-1 (rpm) (speed) is too high or you release the clutch lever too quickly, your Cota may lurch forward.
5. When you attain a moderate speed, close the throttle, pull the clutch lever in, and raise the shift lever. After shifting, release the clutch lever and apply the throttle.
6. To continue shifting up to each higher gear, repeat step 5.
7. To shift down to a lower gear, close the throttle, pull the clutch lever in, and depress the shift lever. After shifting, release the clutch lever and apply the throttle.