

- (1) BOLT
- (2) SPRING WASHER
- (3) DRIVE SPROCKET

Drive/Driven Sprockets

Drive Sprocket Replacement

Remove the drive sprocket cover.
Loosen the drive chain fully.

Insert 1st gear

Remove the screw drive pinion and spring washer.

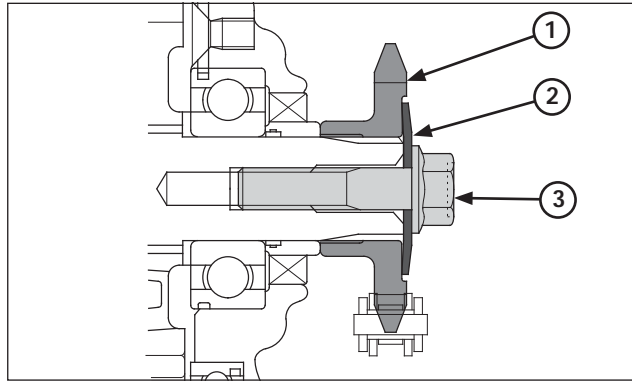

- (1) DRIVE SPROCKET
- (2) SPRING WASHER
- (3) BOLT

Install the drive sprocket onto the countershaft as shown.
Install the spring washer and bolt, then tighten the bolt to the specified torque.

Torque: 31 N•m (3.2 kgf•m, 23 lbf•ft)

Put the transmission in neutral.

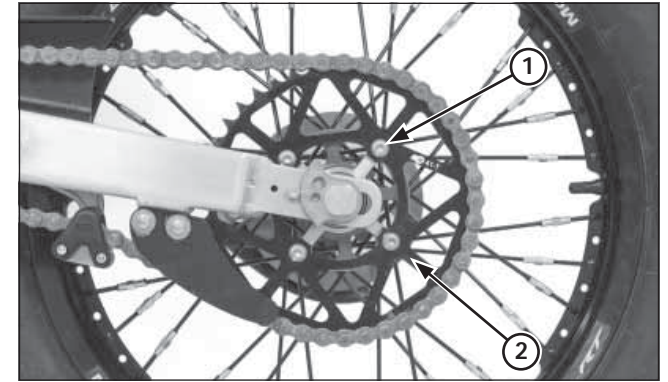

- (1) BOLTS/NUT
- (2) DRIVEN SPROCKET

Driven Sprocket Replacement

Remove the rear wheel (page 5-15).

Remove the bolts/nuts, washers and driven sprocket.

Installation is in the reverse order of removal.

Hold the bolts and tighten the nuts to the specified torque.

Torque: 30 - 35 N•m (3.0 - 3.5 kgf•m, 22.1 - 25.8 lbf•ft)

Adjust the drive chain slack (page 3-11).