

Operating instructions

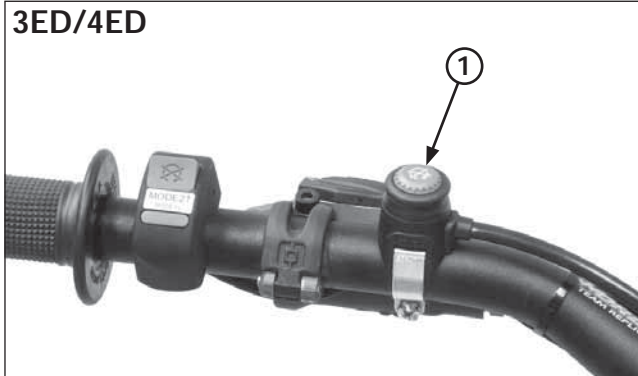
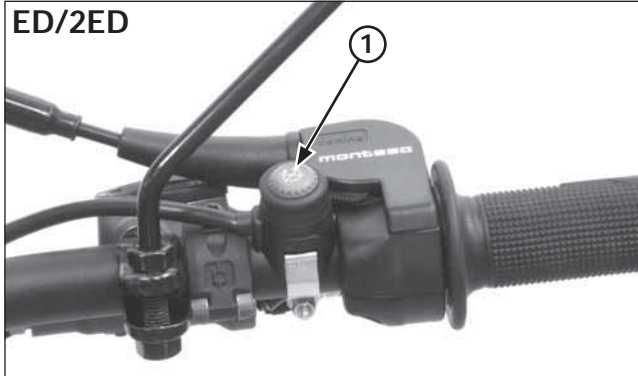

(1) ENGINE STOP BUTTON

When you shift the transmission into gear, apply front brake to prevent the motorcycle move forward.

Stopping The Engine

1. Shift the transmission into neutral.
2. Push the engine stop button until the engine stops completely.

Break-In Procedure

New Motorcycle

Following proper break-in procedure helps ensure that the most important and expensive components on your new motorcycle will provide maximum performance and service life. (Also follow proper break-in procedure for a newly rebuilt engine.)

When riding a new motorcycle, operate the motorcycle for the first 20 minutes using not more than half throttle and shifting gears so that the engine does not lug:

Reconditioned Motorcycle

- After replacing the cylinder and crankshaft, operate the motorcycle 20 minutes observing the same cautions as for a new motorcycle.
- When the piston, piston ring, gears, etc. are replaced, they must be broken in observing the first 30 minutes using not more than half throttle and shifting gears so that the engine does not lug

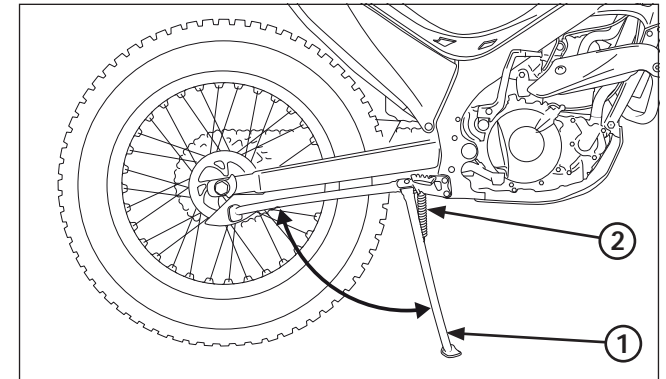

(1) SIDE STAND

(2) SIDE STAND SPRINGS

Side Stand

The side stand is used to support your Cota while parked. To operate, use your foot to lower the side stand until it is fully extended.

Before riding, raise the side stand.

Inspection

1. Check the stand springs for damage or loss of tension.
2. Check the side stand assembly for freedom of movement.

If the stand is stiff or squeaks, clean the area around the pivot and lubricate the pivot bolt with grease or oil lubricant.

NOTICE

Do not start the motorcycle while supported on the side stand, which could be bent.