

Using a 45° seat cutter, cut the seat to proper width. Make sure all pitting and irregularities are removed. Refinish if necessary.

After refacing, wash the cylinder head and valves. After cutting the seats, apply lapping compound to the valve face, and lap the valve using light pressure. After lapping, wash any residual compound off the cylinder head and valve.

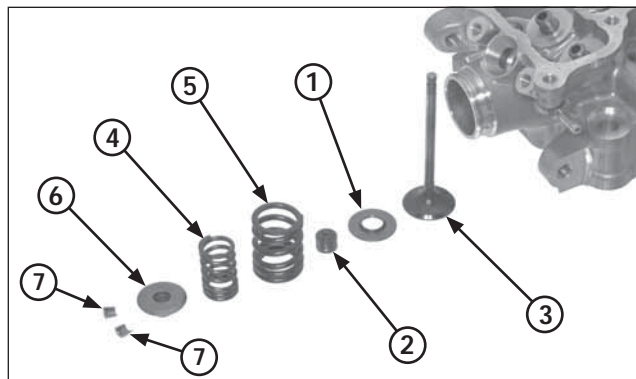

- (1) SPRING SEAT
- (2) STEM SEAL
- (3) VALVE
- (4) INNER SPRING
- (5) OUTER SPRING
- (6) RETAINER
- (7) COTTERS

### Cylinder Head Assembly

Blow out all oil passages in the cylinder head with compressed air. Install the spring seat and new stem seal.

Lubricate the valve stem sliding surface with molybdenum solution. Insert the valves into the guide while turning it slowly to avoid damage to the stem seal.

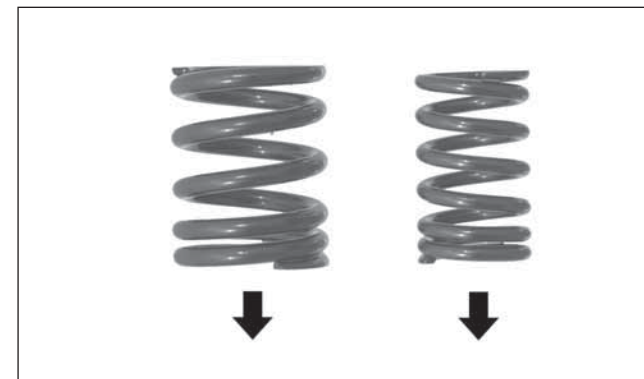

Install the valve springs with the tightly wound coils facing the combustion chamber. Install the spring retainers.