

Engine servicing

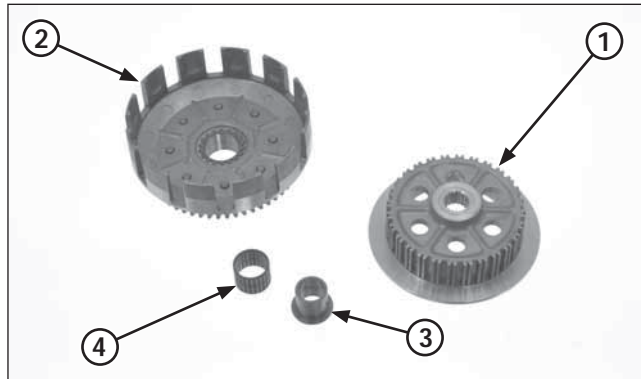

- (1) CLUTCH CENTER
- (2) CLUTCH OUTER
- (3) OUTER GUIDE
- (4) NEEDLE BEARING

Inspection

Check the following items (page 2-2).

- Clutch outer for wear, cracks or indentation by the clutch discs.
- Clutch center grooves for damage, crack or indentation by the clutch plates.
- Clutch outer needle bearing for wear or damage.
- Clutch spring free length
- Clutch disc thickness
- Clutch plate warpage
- Clutch outer I.D.
- Clutch outer guide I.D. and O.D.
- Clutch pressure plate for wear or damage
- Mainshaft O.D. at clutch outer guide

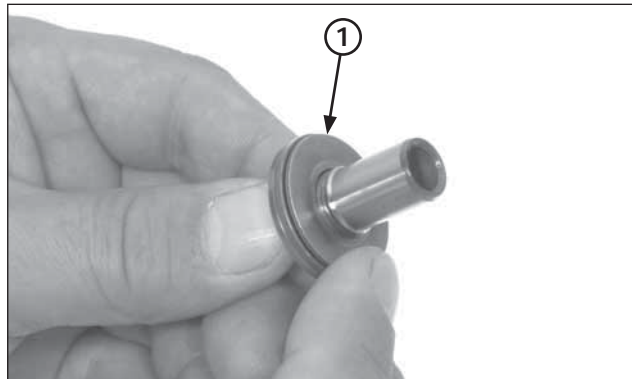

- (1) LIFTER PIECE ASSEMBLY

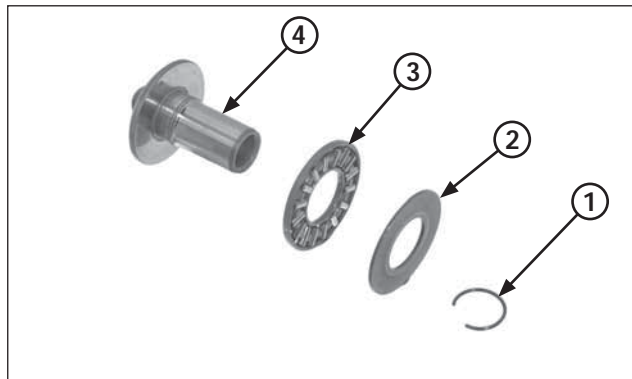

- (1) CIRCLIP
- (2) THRUST WASHER
- (3) THRUST NEEDLE BEARING
- (4) LIFTER PIECE

Check the lifter piece needle bearing by turning the thrust washer with your finger.
If the bearing movement is not smooth, disassemble and replace the bearing.

Remove the circlip, thrust washer and thrust needle bearing from the lifter piece.
Assemble the lifter piece in the reverse order of removal.

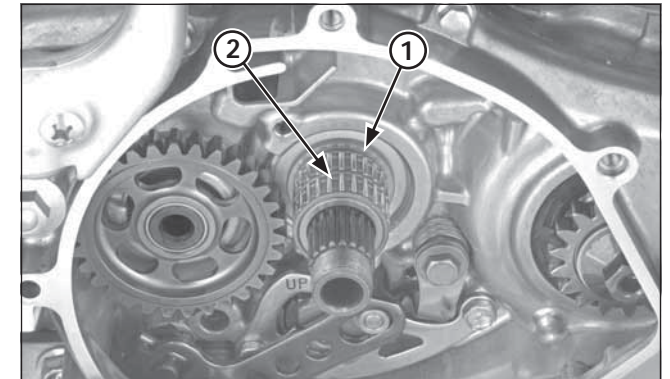

- (1) OUTER GUIDE
- (2) NEEDLE BEARING

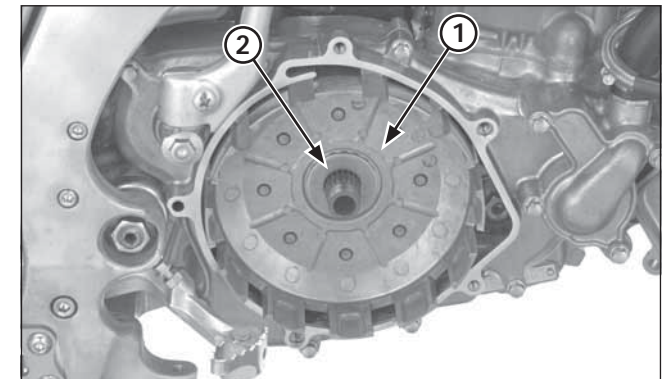

- (1) CLUTCH OUTER
- (2) THRUST WASHER

Installation

Install the clutch outer guide and needle bearing onto the mainshaft.

Install the clutch outer and thrust washer.