

Frame servicing

ED/3ED

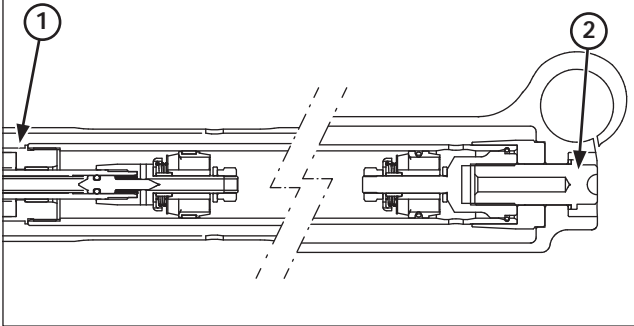

2ED/4ED

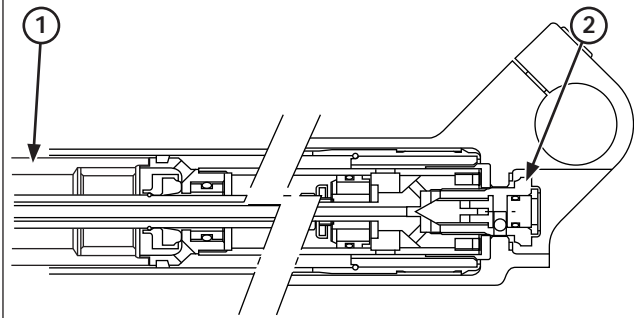

- (1) FORK DAMPER
- (2) RIGHT FORK CENTER BOLT

Hold the axle holder in a vise protected with a piece of woods or soft jaws to avoid damage.
Do not overtighten.

Hold the fork damper using the special tool (2ED/4ED), then loosen the right fork center bolt.

Remove the center bolt and sealing washer.

Tool:
Fork damper holder 89515-NN3-821

ED/3ED

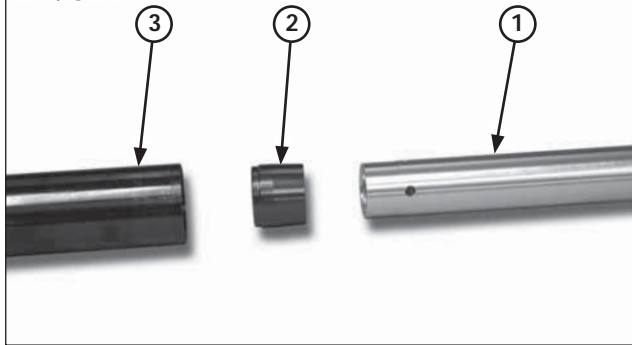

2ED/4ED

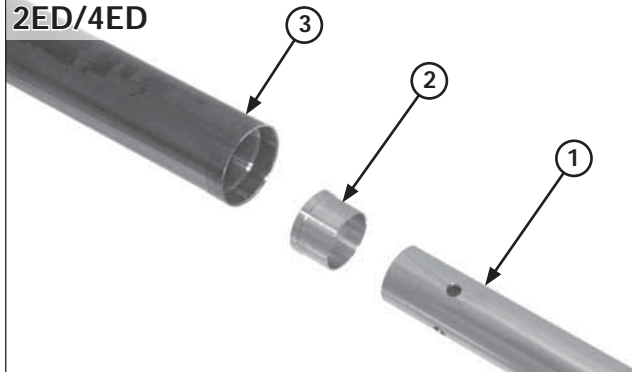

- (1) FORK DAMPER
- (2) CENTERING PLATE
- (3) FORK TUBE

Remove the fork damper assembly and centering plate from the fork tube.

ED/3ED

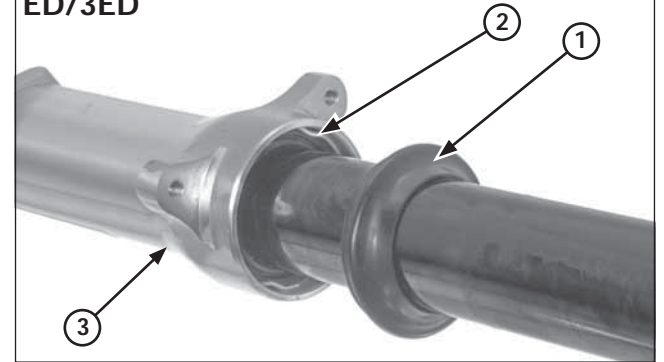

- (1) DUST SEAL
- (2) STOP RING
- (3) FORK SLIDER

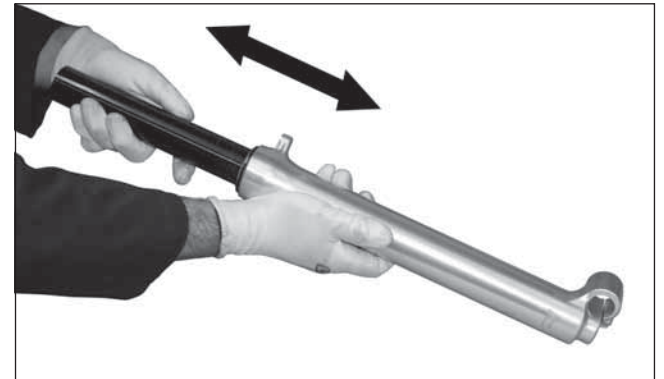

Remove the dust seal and stop ring being careful not to scratch the fork tube.

In quick successive motions, pull the fork tube out of the slider.
Empty the fork fluid from the damper by pumping the damper rod 8 - 10 times.