

(1) FILLER NECK

4. Fill the radiator with coolant up to the filler neck.
5. Squeeze the radiator hoses alternately. If the coolant level drops, fill the coolant again.
6. Fill the radiator with coolant up to the filler neck.
7. After this first filling, start the engine, check the coolant level (page 1-3).

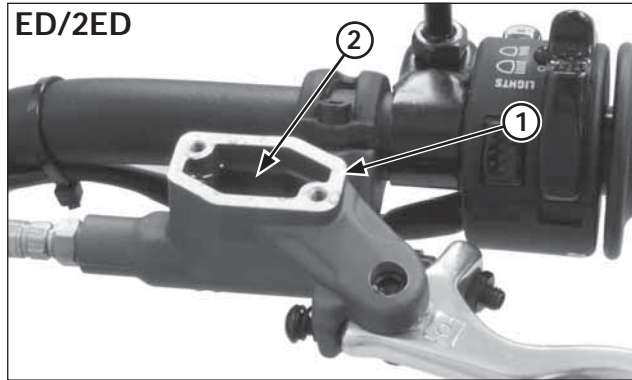

ED/2ED

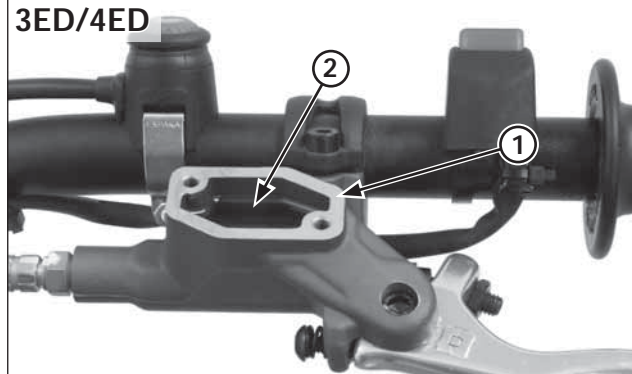

3ED/4ED

- (1) CLUTCH FLUID RESERVOIR
(2) LOWER LEVEL LINE

Clutch System

System Inspection

1. Operate the clutch lever and check that no air has entered in the system. If the clutch is not disengaged properly, or the lever feels soft or spongy, bleed the air from the system.
2. Remove the reservoir cover and diaphragm, check the clutch fluid level. If the level is low, inspect the clutch hose and fittings for damage, deterioration, cracks or sign of leakage. Tighten any loose fittings. Replace hose and fittings as require.

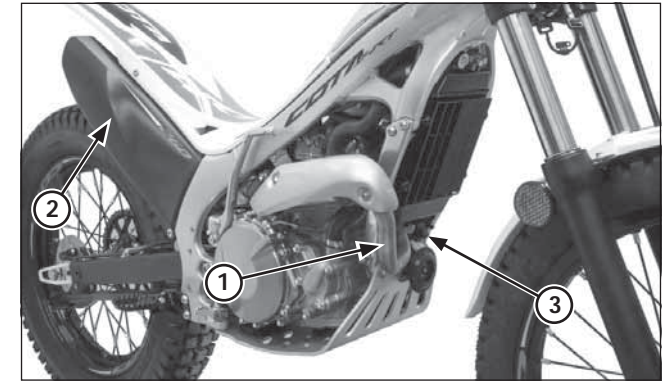

- (1) EXHAUST PIPE
(2) MUFFLER
(3) LAMBDA-SONDE (ED/2ED)

Exhaust Pipe And Muffler

Inspection

- Check the muffler for clogging.
Check for loose or missing bolts and nuts.
Check the exhaust pipe and muffler for cracks or deformation.
Check the exhaust pipe gasket.
Check the muffler gasket.

Loss of power will result if the exhaust pipe is broken.