

(1) CAM CHAIN GUIDE  
(2) ALIGN

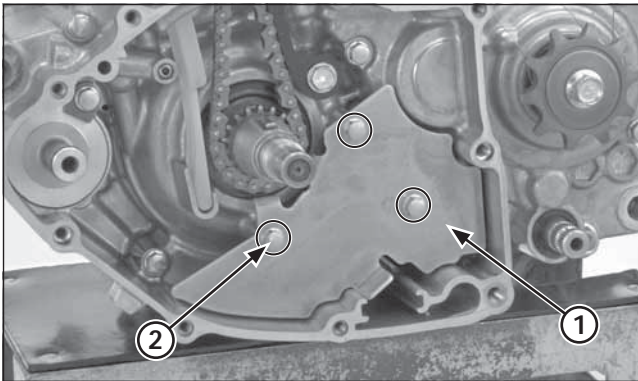

(1) CAM CHAIN GUIDE PLATE  
(2) BOLTS

Install the cam chain guide by aligning the guide end with the groove in the crankcase and the tab with the groove in the cylinder.

Install the cam chain guide plate and tighten the bolts.

Install the following:

- Flywheel (page 4-53)
- Left crankcase cover (page 4-50)
- Cylinder head (page 4-37)

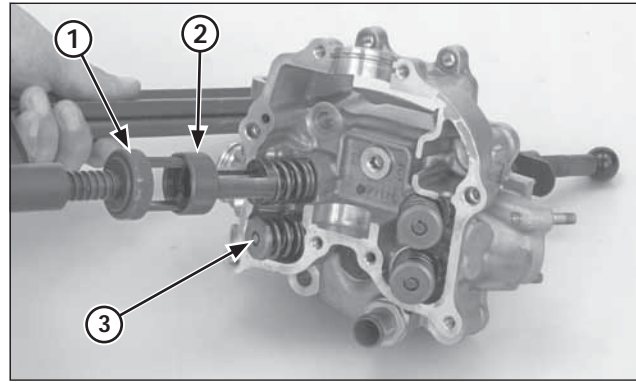

(1) VALVE SPRING COMPRESSOR  
(2) ATTACHMENT  
(3) COTTERS

### Cylinder Head Disassembly

Remove the cylinder head (page 4-23).

Remove the valve spring cotters using the special tools. To prevent loss of tension, do not compress the valve springs more than necessary to remove the cotters.

Tools:

- |                         |               |
|-------------------------|---------------|
| Valve spring compressor | 07757-0010000 |
| Compressor attachment   | 07959-KM30101 |

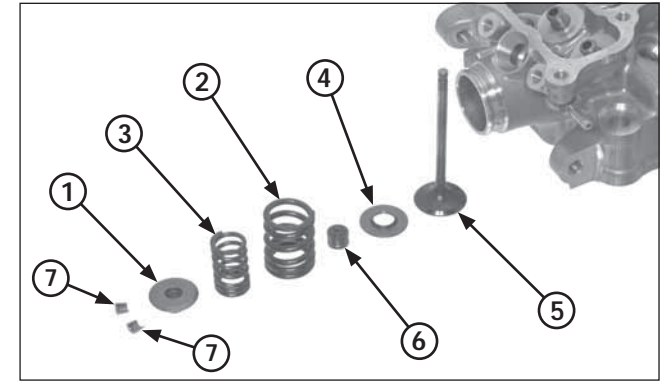

(1) RETAINER  
(2) OUTER SPRING  
(3) INNER SPRING  
(4) SPRING SEAT  
(5) VALVE  
(6) STEM SEAL  
(7) COTTERS

Remove the following:

- Spring retainer
- Outer and inner valve springs
- Stem seal
- Valve spring seat
- Intake and exhaust valve