

(1) ROUGHNESS

- Contact area (too high or too low)
- Reface the valve seat.

The valves cannot be ground, If a valve face is burned or badly worn or if it contacts the seat unevenly, replace the valve.

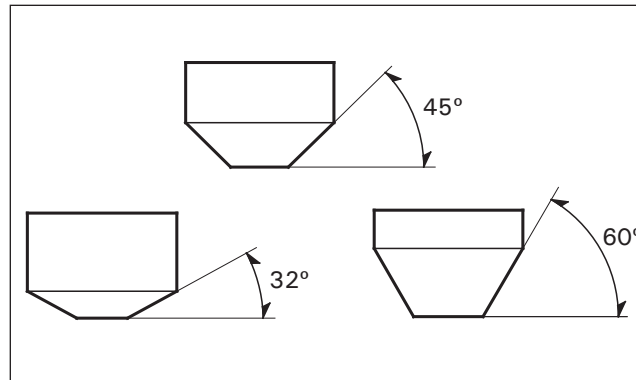

#### Valve Seat Refacing

Valve seat cutters, grinders or equivalent valve seat refacing equipment are recommended to correct worn valve seat. Follow the refacing manufacturer's instructions.

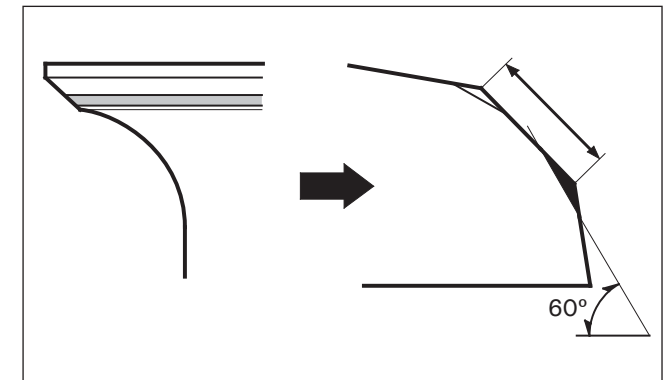
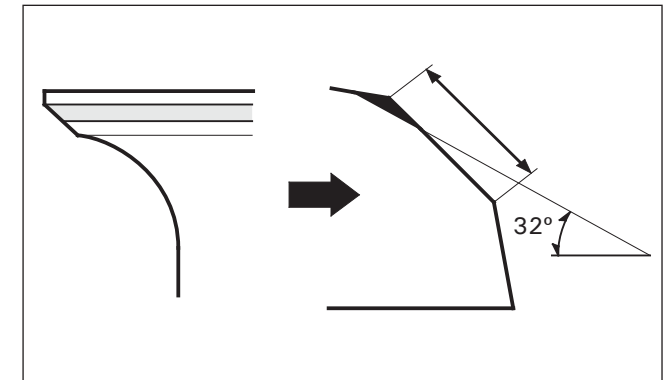

If the contact area is too high on the valve, the seat must be lowered using a 32° flat cutter.

If the contact area is too lower on the valve, the seat must be raised using a 60° interior cutter.