

- (1) MAINSHAFT
- (2) COUNTERSHAFT
- (3) SHIFT FORK SHAFTS
- (4) LEFT SHIFT FORK
- (5) RIGHT SHIFT FORK
- (6) CENTER SHIFT FORK

Crankcase Combination

Clean the crankcase mating surfaces before assembling and check for wear or damage.

If the minor roughness or irregularities on the crankcase mating surfaces, dress them with an oil stone.

Lubricate the crankshaft bearing with engine oil.

Lubricate the transmission bearings with transmission oil.

Install the crankshaft into the right crankcase.

Install the mainshaft and countershaft as an assembly into the right crankcase.

Install the center shift fork with its identification mark facing in.

Install the right and left shift forks with their identification marks facing out.

Install the shift drum.

Install the shift forks.

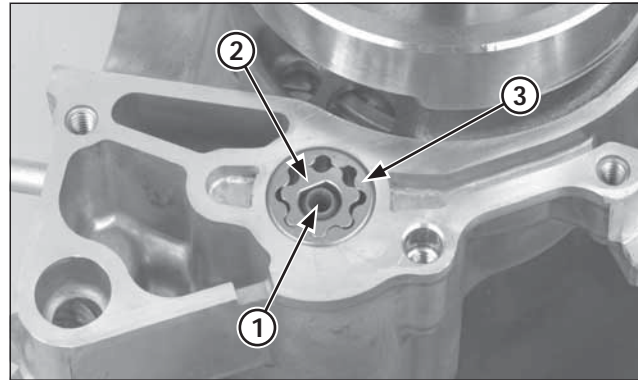

- (1) OIL PUMP SHAFT
- (2) INNER ROTOR
- (3) OUTER ROTOR

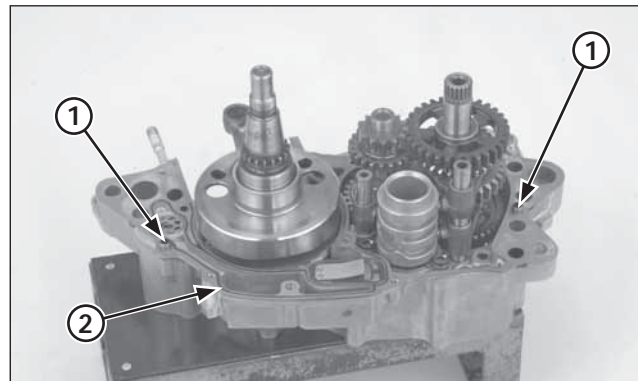

- (1) DOWEL PINS
- (2) NEW GASKET

Install the oil pump shaft, oil pump inner rotor and outer rotors.

Install the dowel pins and new gasket.

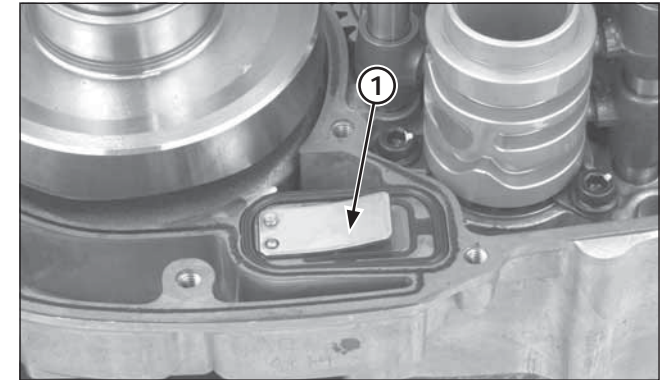

- (1) ONE-WAY REED VALVE

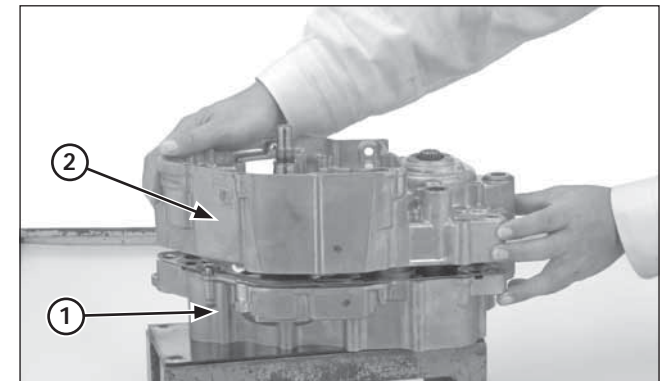

- (1) RIGHT CRANKCASE
- (2) LEFT CRANKCASE

Install the one-way reed valve into the right crankcase.

Place the left crankcase onto the right crankcase.