

## Frame servicing

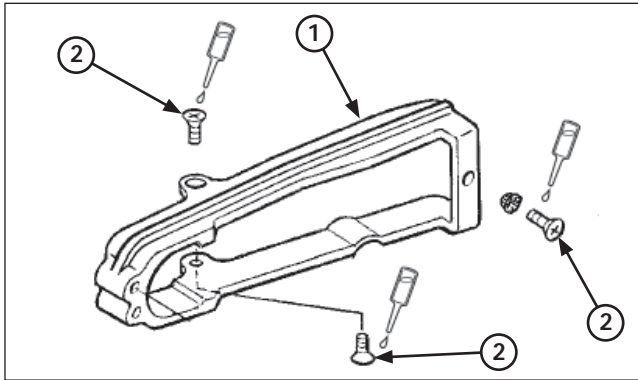

- (1) DRIVE CHAIN SLIDER
- (2) SCREWS

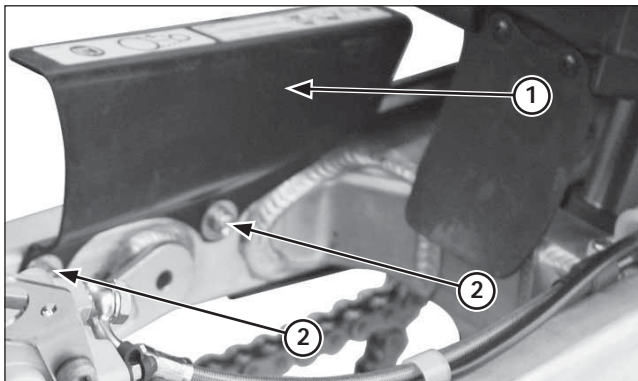

- (1) DRIVE CHAIN GUARD
- (2) SCREWS

Install the drive chain sliders onto the swingarm.  
Apply a locking agent to the drive chain slider screw threads and tighten the screw.

Install the drive chain guard and tighten the bolts.

**Torque: 6 - 7 N•m (0.6 - 0.7 kgf•m, 4.4 - 5.1 lbf•ft)**

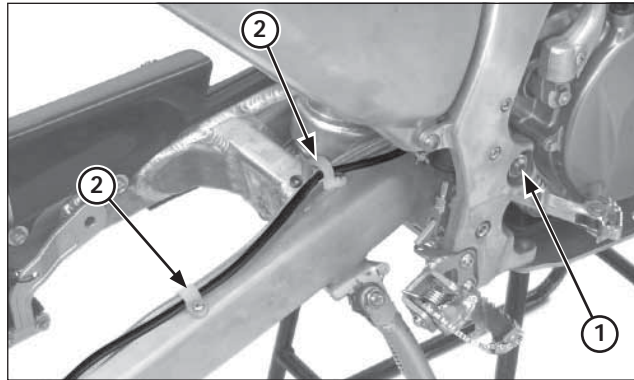

- (1) PIVOT BOLT/NUT
- (2) HOSE CLAMPS

### Installation

Apply thin coat of grease to the swingarm pivot bolt surface.  
Install the swingarm into the frame.  
Install the swingarm pivot bolt from the left side.  
Install and tighten the swingarm pivot nut to the specified torque.

**Torque: 69 N•m (7.0 kgf•m, 51 lbf•ft)**

Install the brake caliper onto the swingarm rail.  
Install the brake hose clamps and tighten the screws.

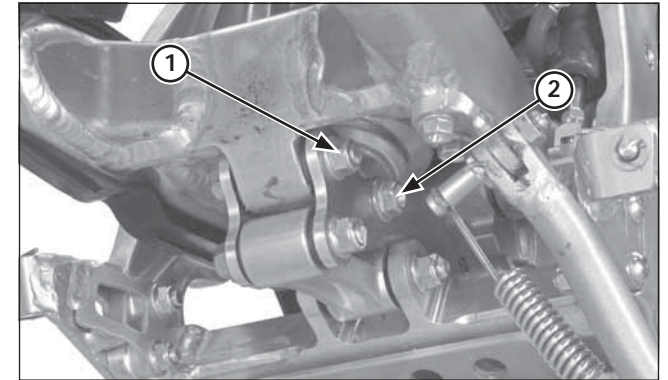

- (1) SHOCK ARM PLATES-TO-SWINGARM BOLT/NUT
- (2) SHOCK ABSORBER LOWER MOUNTING BOLT/NUT

Install the following:

- Shock arm plates-to-swingarm bolt/nut
- Rear cushion lower mounting bolt/nut

Tighten the shock arm plate bolt.

**Torque: 39 N•m (4.0 kgf•m, 29 lbf•ft)**

Tighten the shock absorber lower mounting bolt to the specified torque.

**Torque: 39 N•m (4.0 kgf•m, 29 lbf•ft)**

Install the rear wheel (page 5-16)