

(1) CALIPER PISTON

Rear Brake Pad Replacement (3ED/4ED)

Remove the rear wheel (page 5-15)
 Push the piston all the way in to allow installation of new brake pads.
 Check the brake fluid level in the reservoir as this operation causes the level to rise.
 Remove the pad pin and brake pads.
 Clean the brake caliper inside especially around the caliper pistons.

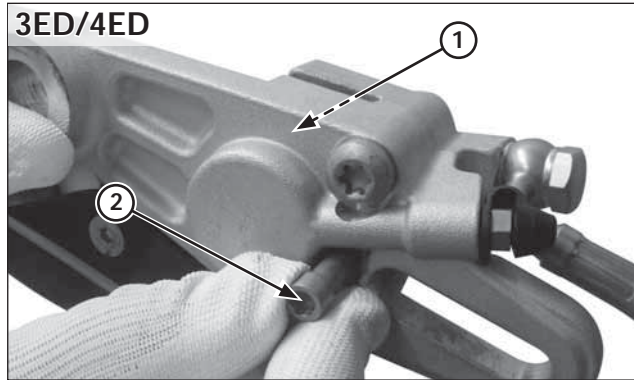

(1) BRAKE PADS
 (2) PAD PIN

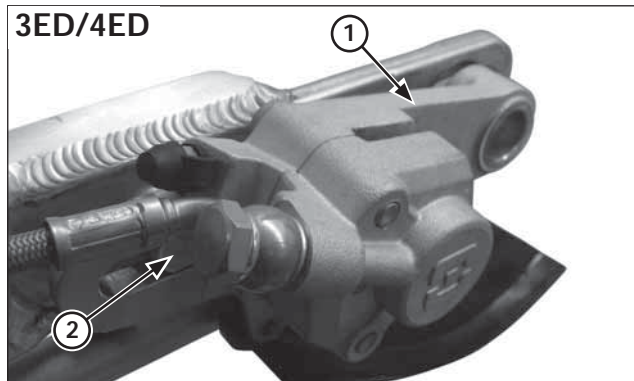

(1) CALIPER BRACKET
 (2) BOSS/SPLIT

Install the new pads and secure them with the pad pin.

Install the brake caliper bracket aligning its slit with the boss on the swingarm.

Install the rear wheel (page 5-16).
 Operate the brake pedal to seat the caliper pistons against the pads.

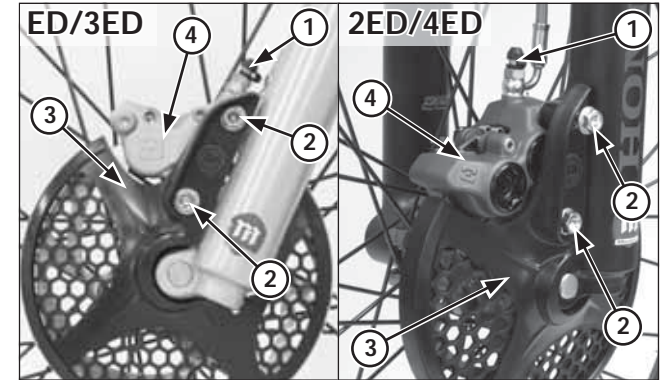

(1) BRAKE HOSE OIL BOLT
 (2) MOUNTING BOLTS
 (3) DISC COVER
 (4) BRAKE CALIPER

Front brake caliper

Removal

NOTICE

*Avoid spilling brake fluid on painted, plastic or rubber parts.
 Place a shop rag over these parts whenever the system is serviced.*

Drain the brake system.
 Place a clean container under the caliper.

Remove the following:

- Brake hose oil bolt
- Sealing washers
- Brake hose eyelet
- Caliper mounting bolts
- Disc cover
- Flange collars
- Brake caliper
- Spring pin for the pads
- Brake pads (page 5-25, ED/3ED version)
 (page 5-26, 2ED/4ED version)