

Frame servicing

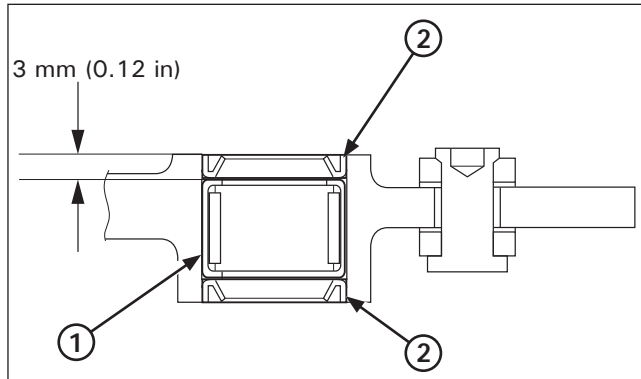

- (1) BEARING
- (2) DUST SEALS

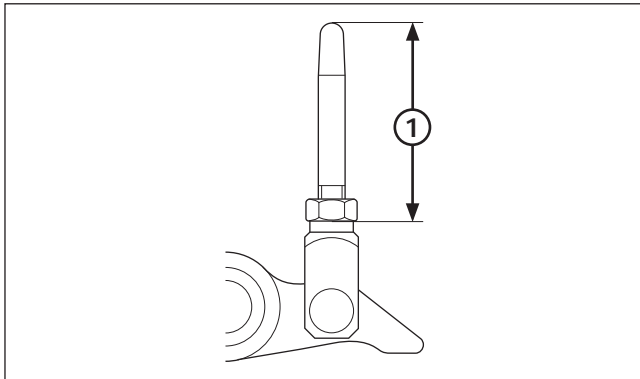

- (1) STANDARD LENGTH; 35 MM

Pivot Bearing Replacement

Remove the dust seals.

Remove the pivot bearing and press a new needle bearing so that it is 3 mm (0.12 in) below the pedal end. Apply grease inside needle bearing.

Adjust the brake pedal height by loosening the lock nut and turning the push rod.

Push rod height must be adjusted between 32.5 – 37.5 mm.

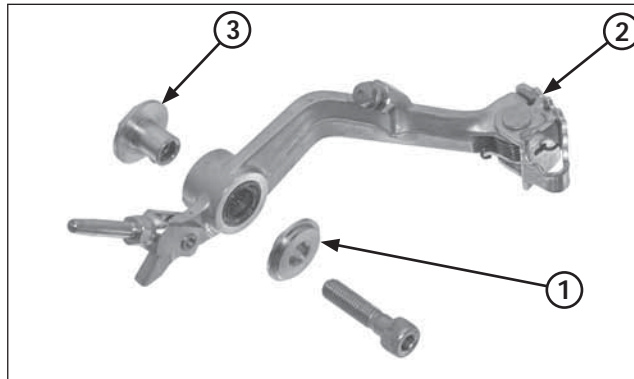

- (1) COLLAR B
- (2) PEDAL
- (3) COLLAR A

Installation

Install the brake pedal and collars.
Install and tighten the pivot nut and bolt.
Apply sealant to the threads of pivot bolt.

Torque: 29 N•m (3.0 kgf•m, 22 lbf•ft)

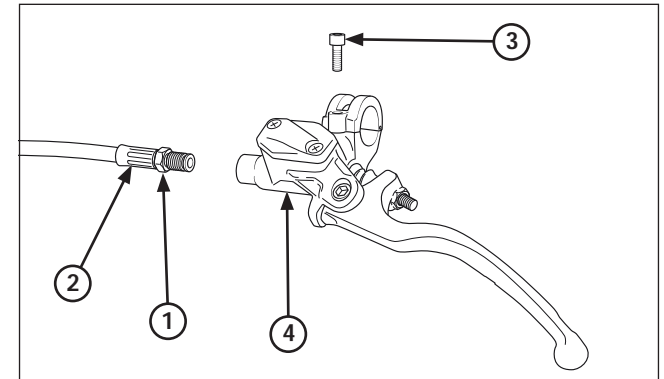

- (1) OIL BOLT
- (2) CLUTCH HOSE
- (3) BOLT
- (4) MASTER CYLINDER

Clutch master cylinder

Removal/Installation

NOTICE

Avoid spilling brake fluid on painted, plastic or rubber parts. Place a shop rag over these parts whenever the system is serviced.

When removing the clutch hose bolt, cover the end of the hose to prevent contamination. Secure the hose to prevent fluid from leaking out.

Drain the clutch fluid from the hydraulic system into a suitable container.

Remove the following:

- Clutch lever
- Clutch hose bolt
- Master cylinder holder bolt and holder
- Master cylinder