

**FRONT AXLE INSPECTION**

Set the axle in V-blocks, rotate and measure the runout.

Actual runout is 1/2 of the total indicator reading.

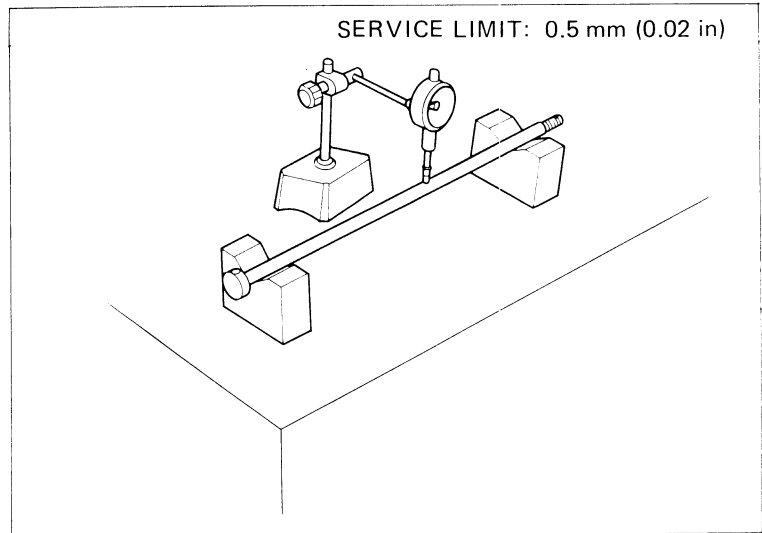

**WHEEL BEARING INSPECTION**

Check the wheel bearings by placing the wheel between V-blocks and spinning the wheel by hand.

Replace the bearings with new ones if they are noisy or have excessive play.

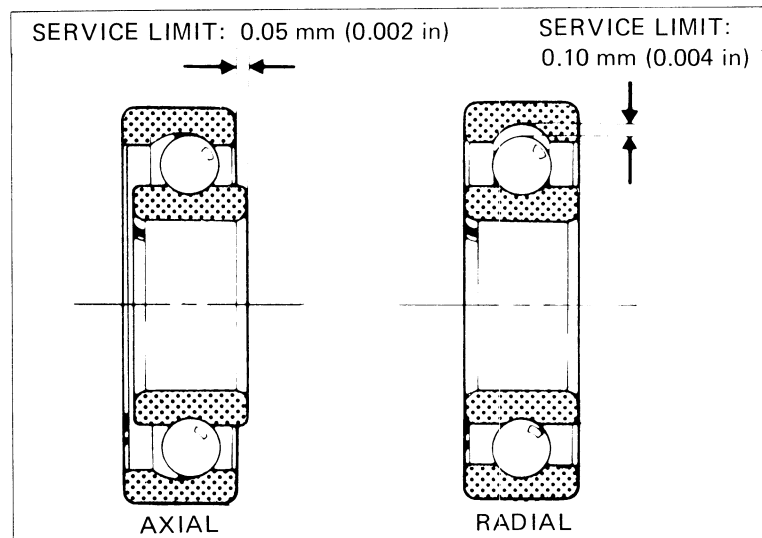

Remove the dust seals.  
Drive the bearings and center collar out.

