

CYLINDER HEAD/VALVES

VALVE SEAT REFACING

Use a 45 degree cutter to remove any roughness or irregularities from the seat.

NOTE

Reface the seat with a 45 degree cutter when a valve guide is replaced.

Use a 32 degree cutter to remove the top 1/4 of the existing valve seat material.

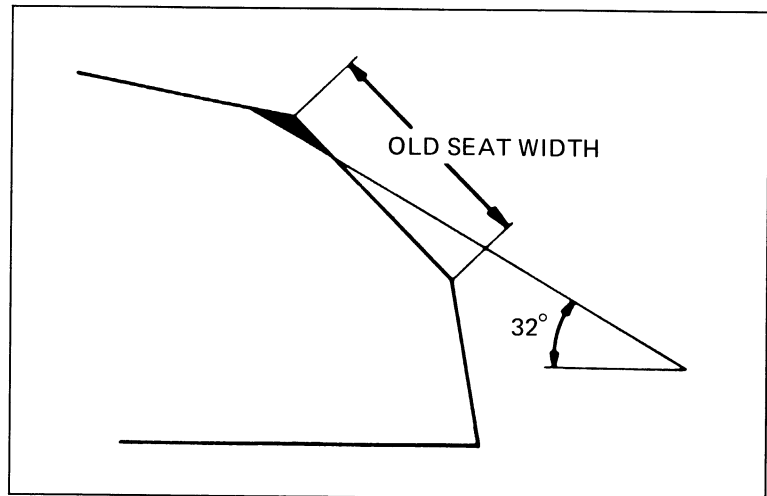

Use a 60 degree cutter to remove the bottom 1/4 of the old seat. Remove the cutter and inspect the area you have refaced.

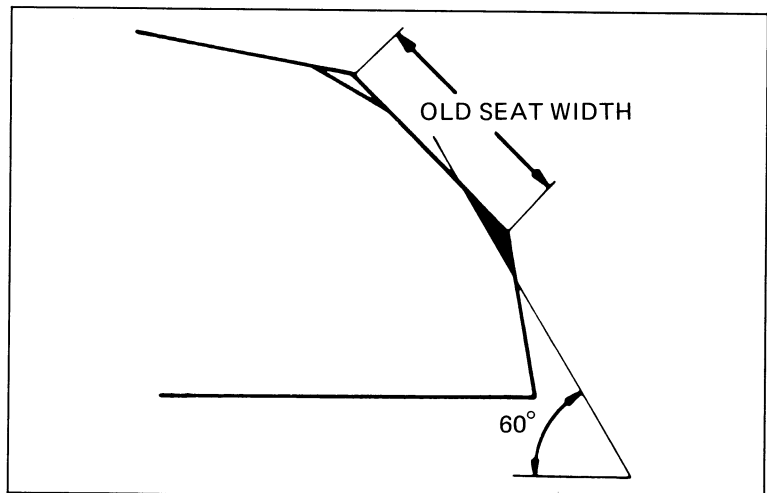

Install a 45 degree finish cutter and cut the seat to the proper width. Make sure that all pitting and irregularities are removed. Refinish if necessary.

