

CRANKCASE/CRANKSHAFT/TRANSMISSION

Contact is normal if Prussian Blue is transferred to the approximate center of each tooth and slightly to the side.

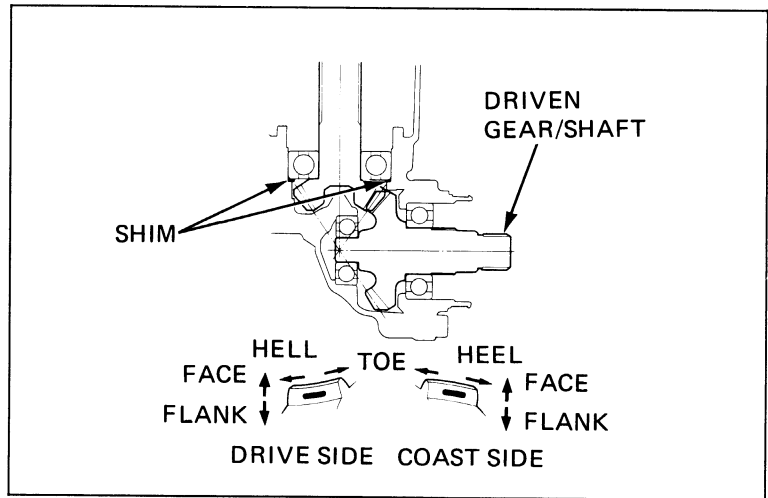

If the pattern is not correct, remove and replace the drive gear adjustment shim.

Replace the shim with a thinner one if the contact pattern is too high.

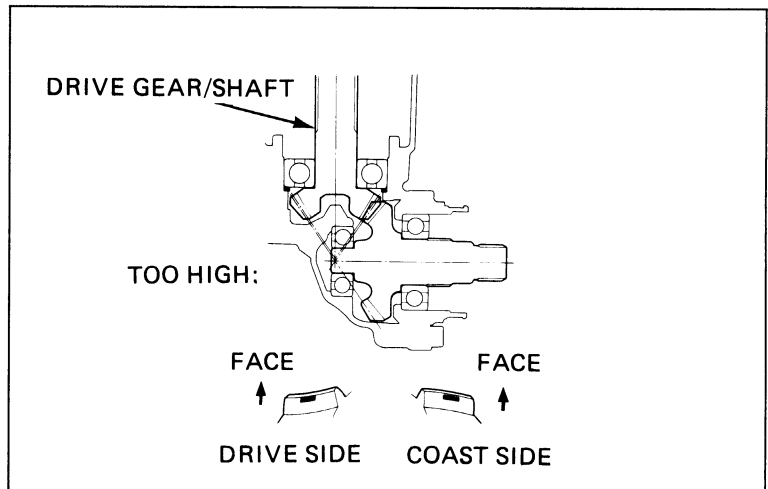

Replace the drive gear adjustment shim with a thicker one if the contact is too low.

The pattern will shift about 1.0 mm (0.04 in) when the thickness of the shim is changed by 0.10 mm (0.04 in).

OUTPUT DRIVE GEAR ADJUSTMENT SHIM:

- A: 0.90 mm (0.035 in)
- B: 0.95 mm (0.037 in)
- C: 1.00 mm (0.039 in) **STANDARD**
- D: 1.05 mm (0.041 in)
- E: 1.10 mm (0.043 in)
- F: 1.15 mm (0.045 in)
- G: 1.20 mm (0.047 in)

Check the backlash (See page 10-17).

