

Place the slider bushing over the fork tube and rest it on the slider. Put the back-up ring and an old bushing or equivalent tool on the top.

Drive the bushing into place with the fork seal driver and remove the old bushing or equivalent tool.

Wrap tape around the top of the fork tube to prevent damage to the new oil seal.

Coat a new oil seal with ATF and install it with the seal markings facing up. Drive the seal in, until the snap ring groove is visible, with the fork seal driver.

TOOLS:

- (1) FORK SEAL DRIVER 07947—KA50100
- (2) FORK SEAL DRIVER ATTACHMENT 07947—KL40100 or 07947—3710101

Install the snap ring and dust seal.

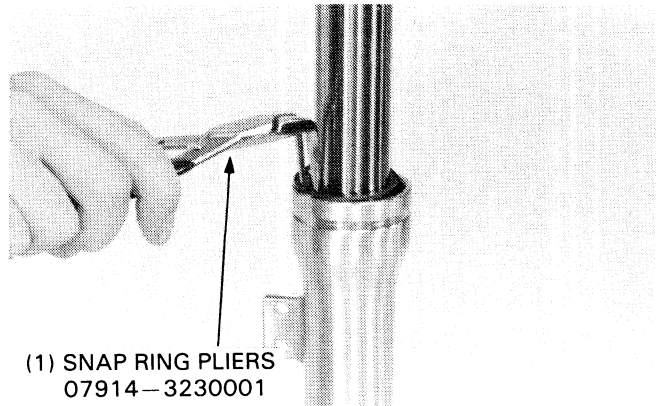
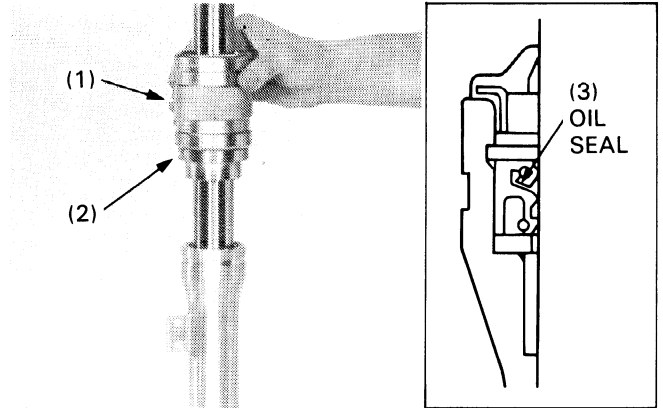

Fill the fork with ATF.

CAPACITY: 290 cc (9.8 US oz, 10.2 Imp oz)

Pump the fork several times.

Compress the fork and measure the ATF level from the top of the tube after the level stabilizes.

SPECIFIED LEVEL: 215 mm (8.5 in)

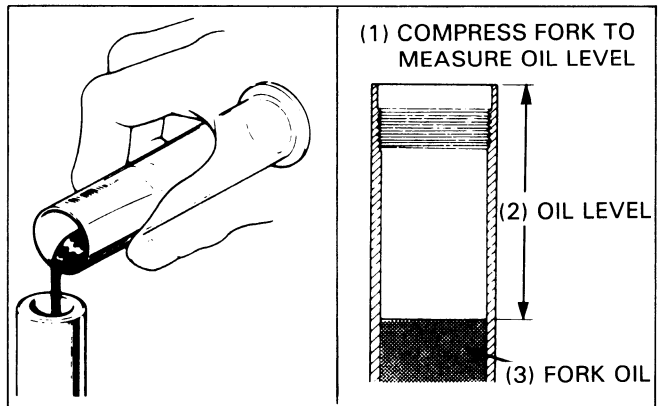

Wipe oil off the spring thoroughly using a clean cloth.

Install the lower fork spring with the tapered end facing down. Install the spring seat and the upper fork spring.

