

Remove the oil bolts and sealing washers, and disconnect the oil hose from the damper and the reservoir.

Drain the oil from the reservoir, hose and damper.

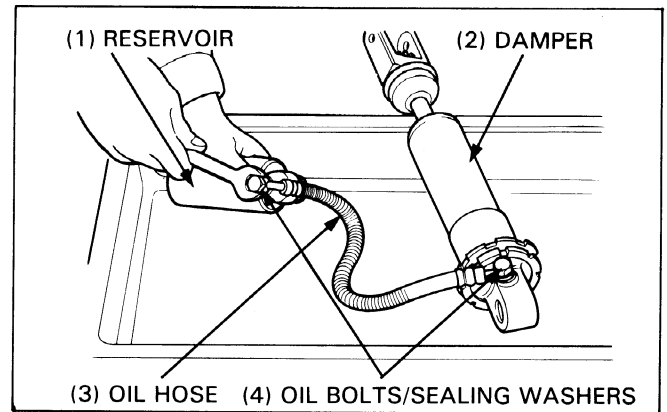

ASSEMBLY

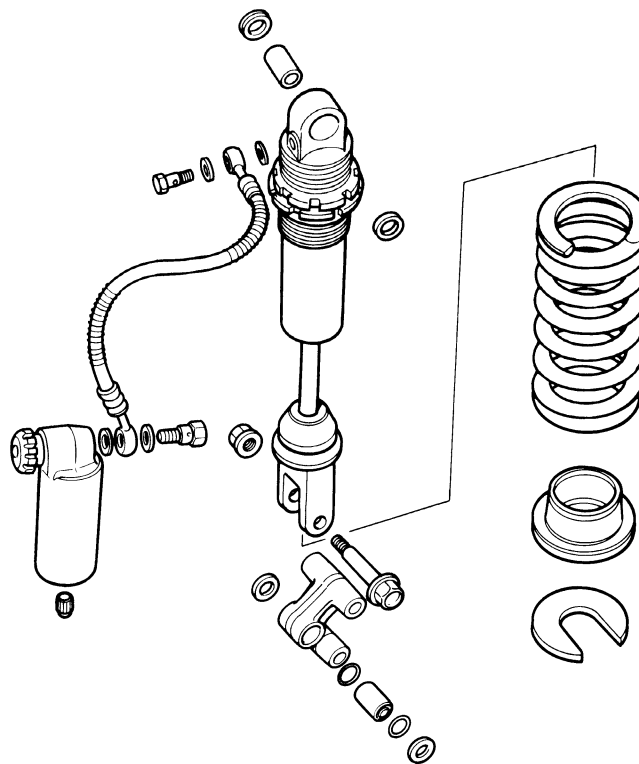

Hold the upper shock mount in a vise with soft jaws or a shop towel. Point the hole straight up.

Pull out the damper rod all the way and fill the damper with ATF.

