

INSPECTION

Check the caliper cylinders and pistons for scratches, scoring or other damage.

Measure the cylinder inside diameter and piston outside diameter.

SERVICE LIMITS:

CYLINDER I.D.: 25.46 mm (1.002 in)

PISTON O.D.: 25.30 mm (0.996 in)

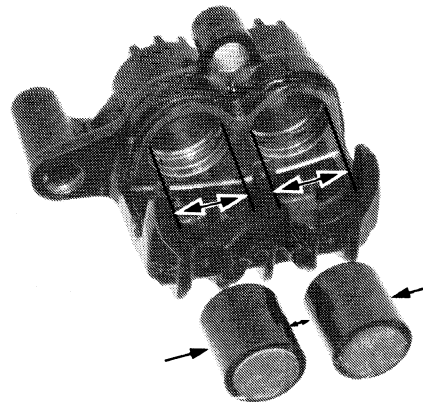

ASSEMBLY

Coat new dust and piston seals with clean brake fluid and install them in the seal grooves in the caliper with their smaller diameter ends facing in.

Lubricate the cylinders and pistons with clean brake fluid and install the pistons into the cylinders with the piston pad end facing the pad side.

Apply silicone grease to the pivot collar and boots and install the boots making sure that they are seated in the caliper grooves properly.

Install the pad spring.

Coat the pins with silicone grease and install the caliper bracket on the caliper.

Install the front brake pads (page 14-7).

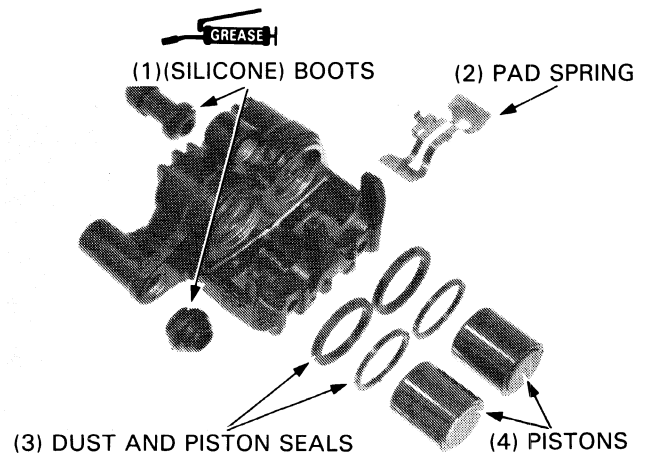

CAUTION

- *Slide the boots into the grooves of the caliper bracket pins.*

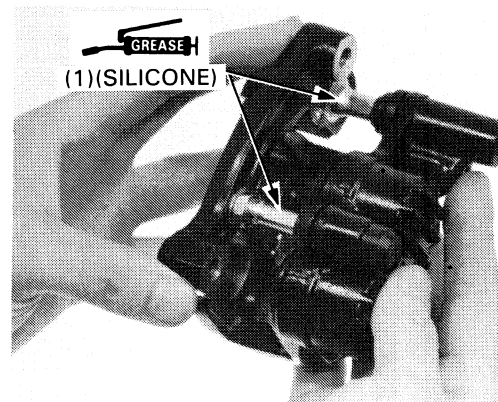

Install the caliper onto the left fork leg and tighten the caliper mounting bolts.

TORQUE: 20 – 30 N·m (2.0 – 3.0 kg·m, 15 – 22 ft·lb)

Connect the front brake hose to the caliper with the oil bolt and two new sealing washers, and tighten the oil bolt.

TORQUE: 25 – 35 N·m (2.5 – 3.5 kg·m, 18 – 25 ft·lb)

Fill the front brake reservoir and bleed the front brake system (page 14-4).

