

# Shifting Gears

Your motorcycle transmission has five forward gears in a one-down, four-up shift pattern.

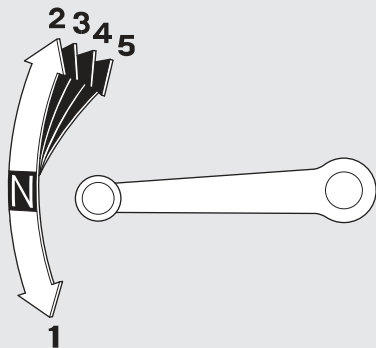

If you put the motorcycle in gear with the side stand down, the engine will shut off.

## Recommended Shift Points

### Shifting Up

From 1st to 2nd	16 mph (25 km/h)
From 2nd to 3rd	22 mph (35 km/h)
From 3rd to 4th	25 mph (40 km/h)
From 4th to 5th	28 mph (45 km/h)

### Shifting Down

From 5th to 4th	28 mph (45 km/h)
From 4th to 3rd	22 mph (35 km/h)

#### NOTICE

Improper shifting can damage the engine, transmission, and drive train. Also, coasting or towing the motorcycle for long distances with the engine off can damage the transmission.