

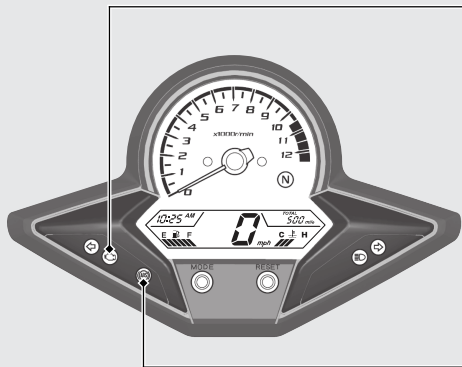

Indicators

If one of these indicators does not come on when it should, have your dealer check for problems.



PGM-FI (Programmed Fuel Injection) malfunction indicator lamp (MIL)

Comes on briefly when the ignition switch is turned to the ON position with the engine stop switch in the  (Run) position.

Comes on when the ignition switch is turned to the ON position with the engine stop switch in the  (Stop) position.

If it comes on while engine is running:

➔ P.88



ABS (Anti-lock Brake System) indicator **CBR300RA**

Comes on when the ignition switch is turned to the ON position. Goes off when your speed reaches approximately 6 mph (10 km/h).

If it comes on while riding: ➔ P.88