

Refer to *Safety Precautions* on page 19.

Clutch Lever Freeplay

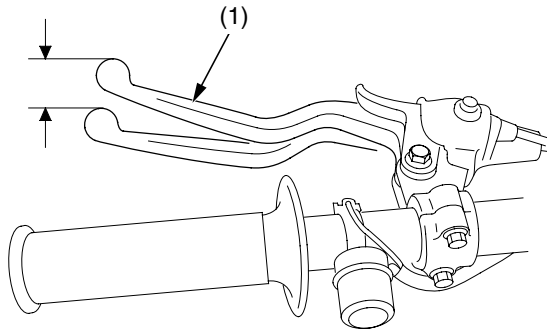

(1) clutch lever

Inspection

Check freeplay.

Freeplay: 3/8 – 13/16 in (10 – 20 mm)

If necessary, adjust to the specified range. Improper freeplay adjustment can cause premature clutch wear.

Make sure to adjust the clutch lever freeplay after the clutch cable is disconnected.

Cable End Adjustment

Minor adjustments are generally made with the cable end adjuster.

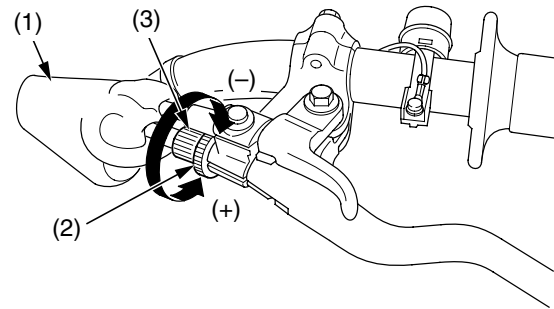

(1) dust cover
(2) lock nut
(3) cable end adjuster

(+) increase freeplay
(-) decrease freeplay

1. Pull the dust cover (1) back.
2. Loosen the lock nut (2) and turn the cable end adjuster (3). Turning the adjuster in direction (-) will decrease freeplay and turning in the direction (+) will increase freeplay.
3. After adjustment, tighten the lock nut and install the dust cover.
4. Check the freeplay again.

If the adjuster is threaded out near its limit or the correct freeplay cannot be reached, turn the adjuster all the way in direction (+) and make the adjustment with the integral cable adjuster.

Integral Cable Adjustment

The integral cable adjuster is used if the cable end adjuster is threaded out near its limit — or the correct freeplay cannot be obtained.

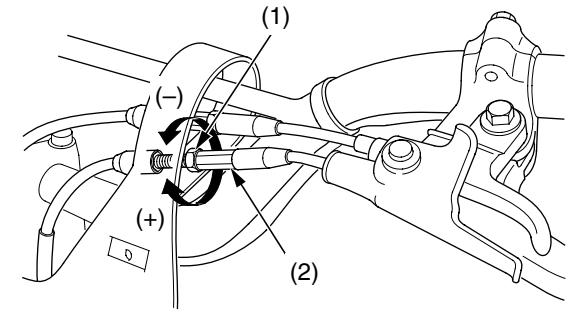

(1) lock nut
(2) integral cable adjuster

(+) increase freeplay
(-) decrease freeplay

1. Turn the cable end adjuster in direction (+) until it seats lightly and then turn it out one turn.
2. Loosen the lock nut (1).
3. Turn the integral cable adjuster (2) to obtain the specified freeplay.
4. Tighten the lock nut. Check the freeplay.
5. Start the engine, pull the clutch lever in, and shift into gear. Make sure the engine does not stall and the motorcycle does not creep. Gradually release the clutch lever and open the throttle. Your CRF should move smoothly and accelerate gradually.

If you can't get proper adjustment, or the clutch does not work properly, the cable may be kinked or worn, or the clutch discs may be worn. See your dealer or refer to the Honda Service Manual (page 148).