

Adding Front Brake Fluid

NOTICE

Spilled brake fluid will severely damage instrument lenses and painted surfaces. It is also harmful to some rubber parts. Be careful whenever you remove the reservoir cap; make sure the reservoir is horizontal first.

- Always use fresh DOT 4 brake fluid from a sealed container when servicing the system. Do not mix different types of fluid, they may not be compatible.
- The recommended brake fluid is Pro Honda DOT 4 brake fluid or an equivalent.

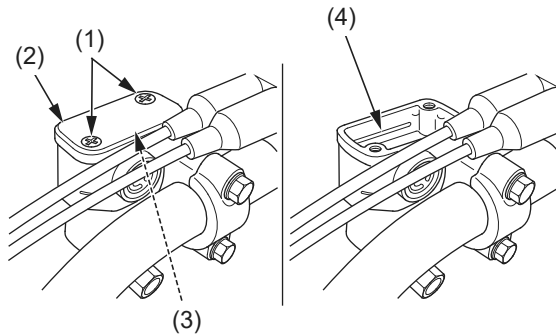

- (1) front brake reservoir cap screws
- (2) reservoir cap
- (3) diaphragm
- (4) upper level mark

1. Remove the front brake reservoir cap screws (1), reservoir cap (2) and diaphragm (3).
2. Fill the reservoir with DOT 4 brake fluid to the upper level mark (4). Do not overfill.
3. Install the diaphragm and reservoir cap.
4. Tighten the front brake reservoir cap screws to the specified torque:
1.1 lbf·ft (1.5 N·m, 0.2 kgf·m)

Adding Rear Brake Fluid

NOTICE

Spilled brake fluid will severely damage instrument lenses and painted surfaces. It is also harmful to some rubber parts. Be careful whenever you remove the reservoir cap; make sure the reservoir is horizontal first.

- Always use fresh DOT 4 brake fluid from a sealed container when servicing the system. Do not mix different types of fluid, they may not be compatible.
- The recommended brake fluid is Pro Honda DOT 4 brake fluid or an equivalent.

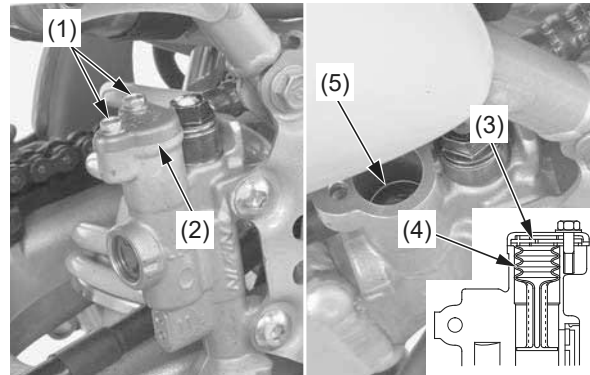

- (1) rear brake reservoir cap bolts
- (2) reservoir cap
- (3) set plate
- (4) diaphragm
- (5) upper level mark

1. Remove the rear brake reservoir cap bolts (1), reservoir cap (2), set plate (3) and diaphragm (4).
2. Fill the reservoir with DOT 4 brake fluid to the upper level mark (5). Do not overfill.

3. Set the diaphragm as shown.
4. Install the set plate and reservoir cap.
5. Tighten the rear brake reservoir cap bolts to the specified torque:
1.1 lbf·ft (1.5 N·m, 0.2 kgf·m)

Other Checks:

Make sure there are no fluid leaks.

Check for deterioration or cracks in the hoses and fittings.