

Always follow the proper starting procedure described below.

Your CRF can be kickstarted with the transmission in gear by pulling in the clutch lever before operating the kickstarter.

Preparation

Make sure that the transmission is in neutral.

Starting Procedure

Always follow the proper starting procedure described as follows.

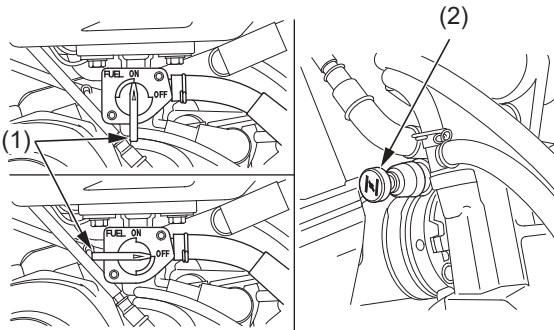

(1) fuel valve

(2) choke knob

Check the engine oil, transmission oil and coolant levels before starting the engine (pages 37, 40, 41). Snapping the throttle or fast idling for more than 5 minutes at normal air temperature may cause exhaust pipe discoloration.

Cold Engine Starting

1. Turn the fuel valve (1) ON.
2. Shift the transmission into neutral.
3. If the temperature is 95°F (35°C) or below, pull the choke knob (2) fully out.
4. If the temperature is below 32°F (0°C), open the throttle two or three times. (The engine requires a richer mixture for starting in cold weather. When the throttle is so opened, the accelerator pump will feed extra fuel to the cylinder, thereby facilitating starting in cold weather.)
5. With the throttle closed, operate the kickstarter starting from the top of the kickstarter stroke, and kick through to the bottom of the stroke with a rapid, continuous motion. (Do not open the throttle, As the carburetor is equipped with an accelerator pump, excessive fuel will be charged into the engine, and the spark plug will be fouled if the throttle is opened and closed repeatedly. Excessive fuel in the engine makes kickstarting difficult.)
6. About a minute after the engine starts, push the choke knob all the way to fully OFF. If idling is unstable, open the throttle slightly.

Warm Engine Starting

1. Turn the fuel valve ON.
2. Shift the transmission into neutral.
3. Pull the hot start lever (1) and kick-start the engine. (Do not open the throttle.)
4. As soon as the engine starts, release the hot start lever.

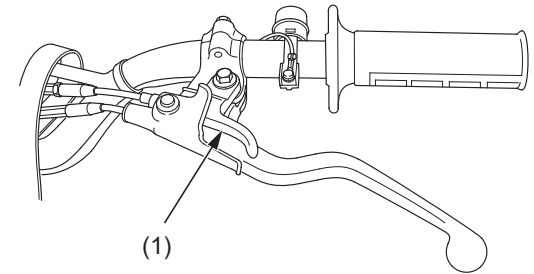

(1) hot start lever

Starting the engine after a stall during riding or after a fall

1. Shift the transmission into neutral.
2. Pull the hot start lever and kick-start the engine (Do not open the throttle).
3. As soon as the engine starts, release the hot start lever.

Flooded Engine

If the engine fails to start after repeated attempts, it may be flooded with excess fuel. To clear a flooded engine:

1. Shift the transmission into neutral.
2. With the throttle fully opened, repeat kickstarter operation approximately ten times very slowly to discharge excessive fuel from the engine.
3. Pull the hot start lever and kick-start the engine. (Do not open the throttle.)
4. As soon as the engine starts, release the hot start lever.