

Clutch Disc/Plate Inspection

- Replace the clutch discs (1) if they show signs of scoring or discoloration.
Measure the thickness of each clutch disc.
Service Limit: 0.112 in (2.85 mm)
Replace the clutch discs and clutch plates as a set.

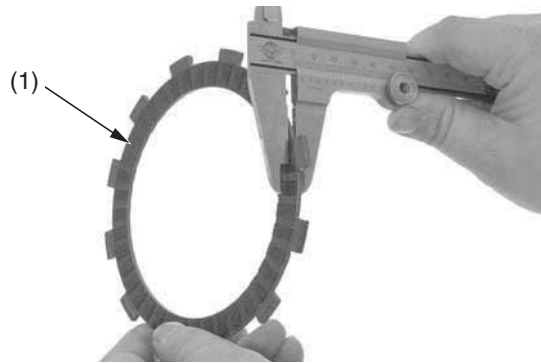

(1) clutch discs

- Check the clutch plates (2) for excessive warpage or discoloration.
Check the plate warpage on a surface plate using a feeler gauge.
Service Limit: 0.004 in (0.10 mm)
Replace the clutch discs and clutch plates as a set.

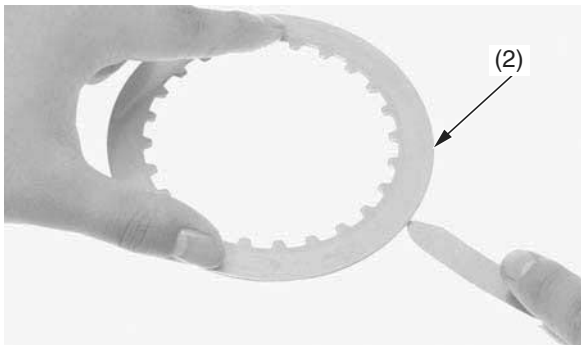

(2) clutch plates

- If you feel the clutch slippage when replacing the clutch discs and plates, replace the clutch springs.

Clutch Disc/Plate Installation

1. Install the spring seat (1) and judder spring (2) onto the clutch center as shown.
Coat the clutch discs with engine oil.
2. Install the clutch disc A (larger I.D. disc) (3) onto the clutch outer.
Stack the seven clutch plates (4) and seven clutch discs B (5) alternately.

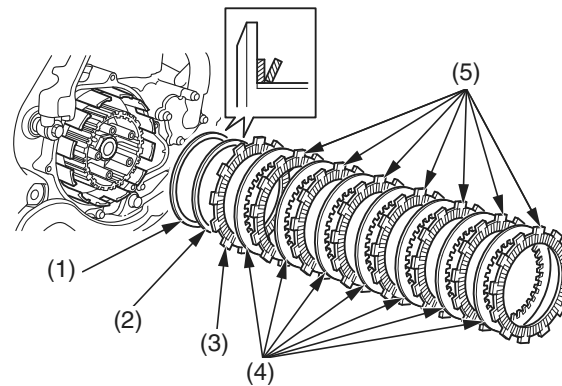

(1) spring seat
(2) judder spring
(3) clutch disc A

(4) clutch plates
(5) clutch discs B

3. Apply engine oil to the needle bearing (6).
Install the needle bearing and washer (7) onto the clutch lifter (8). Then, install a new clip (9) by fitting it into the groove in the clutch lifter.

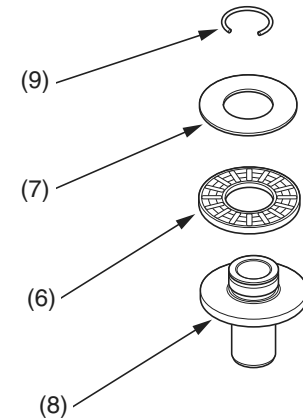

(6) needle bearing
(7) washer

(8) clutch lifter
(9) clip (new)

(cont'd)