

Drive Chain Rollers

Check the upper drive chain roller (1) and lower drive chain roller (2) for wear or damage. Measure the diameter of the drive chain rollers and replace them if below the service limit.

Service Limit:

Upper roller: 1.3 in (33 mm)

Lower roller: 1.2 in (31 mm)

Replace the roller if necessary as follows.

Install the upper drive chain roller (Green) with the “→” mark (3) facing toward the bracket and lower drive chain roller (Black) with the large concave (4) facing outside.

Install the drive chain roller bolt (5) and nut (6).

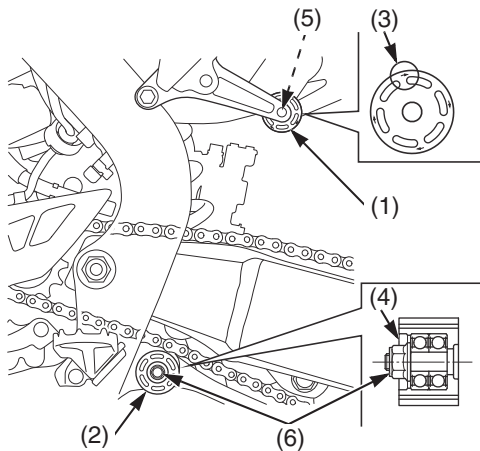

- (1) upper drive chain roller (Green)
- (2) lower drive chain roller (Black)
- (3) “→” mark
- (4) large concave
- (5) drive chain roller bolt
- (6) drive chain roller nut

Clean the threads of the drive chain roller bolt and apply locking agent to the threads.

Tighten the drive chain roller bolt and nut to the specified torque:

9 lbf·ft (12 N·m, 1.2 kgf·m)

Adjustment

1. Loosen the rear axle nut (1).
2. Loosen the chain adjuster lock nuts (2) and turn the adjusting bolts (3) counterclockwise to decrease slack or clockwise to increase slack. Align the index marks (4) of the axle plates (5) with the same reference marks (6) on both sides of the swingarm.

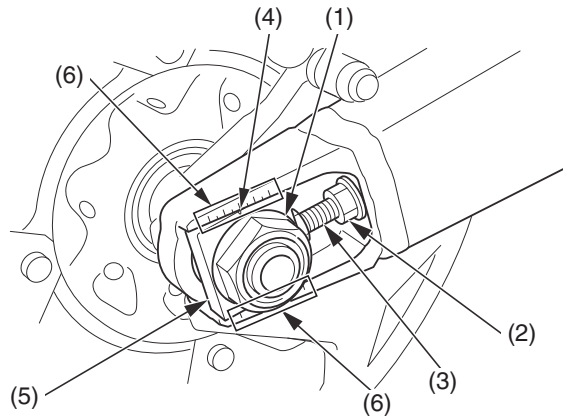

- (1) rear axle nut
- (2) chain adjuster lock nuts
- (3) adjusting bolts
- (4) index marks
- (5) axle plates
- (6) reference marks

3. Tighten the rear axle nut to the specified torque:
94 lbf·ft (128 N·m, 13.1 kgf·m)
4. Recheck chain slack and adjust as necessary.
5. Turn the adjusting bolt counterclockwise until it touches the axle plates lightly. Then tighten the chain adjuster lock nuts to the specified torque while holding the adjusting bolts with a wrench:
20 lbf·ft (27 N·m, 2.8 kgf·m)

Lubrication

Commercially prepared drive chain lubricants may be purchased at most motorcycle shops and should be used in preference to motor oil. Pro Honda HP Chain Lube or an equivalent is recommended.

Saturate each chain joint so that the lubricant penetrates the space between adjacent surfaces of the link plates and rollers.

