

## Crankshaft/Timing Hole Cap Installation

- Coat a new O-rings (1) with engine oil and install them onto the crankshaft hole cap (2) and timing hole cap (3).  
Apply grease to the crankshaft hole cap and timing hole cap threads. Install and tighten the crankshaft hole cap to the specified torque:  
11 lbf·ft (15 N·m, 1.5 kgf·m)  
Install and tighten the timing hole cap to the specified torque:  
4.4 lbf·ft (6.0 N·m, 0.6 kgf·m)

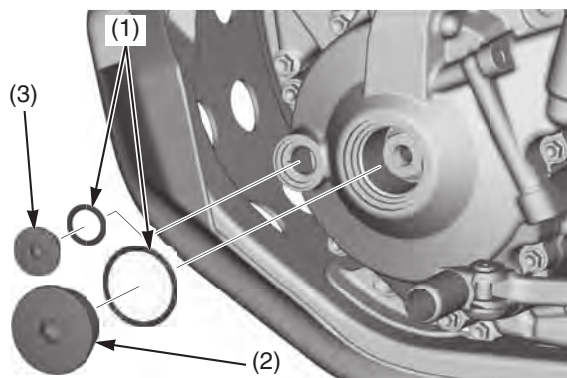

- (1) O-rings (new)  
(2) crankshaft hole cap  
(3) timing hole cap

## Cylinder Head Cover Installation

- Apply liquid sealant (TB1207B or equivalent) to the cylinder head semi-circular cut-outs (1) as shown after cleaning these area.

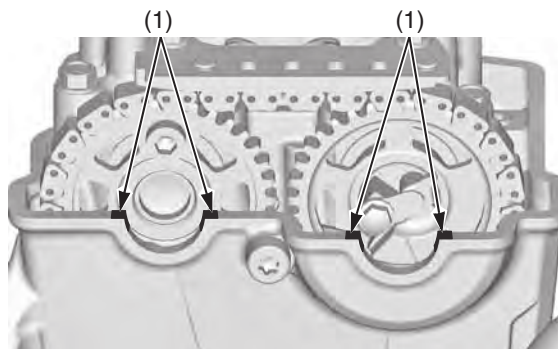

- (1) cylinder head semi-circular cut-outs

- Apply liquid sealant (TB5211B or equivalent) to the cylinder head cover groove (2) as shown after degreasing the groove, and install the cylinder head cover packing (3) into it.

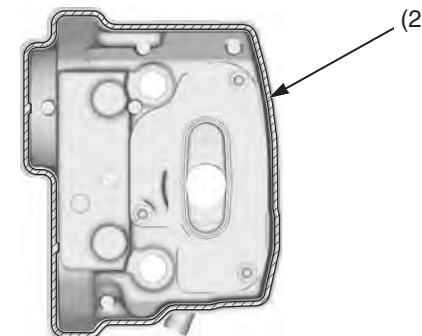

- (2) cylinder head cover groove  
(3) cylinder head cover packing

(cont'd)