

Throttle

Throttle Inspection

1. Check that the throttle assembly is positioned properly (the end of the throttle housing (1) is aligned with the paint mark (2) on the handlebar) and the housing bolts (3) are tight.

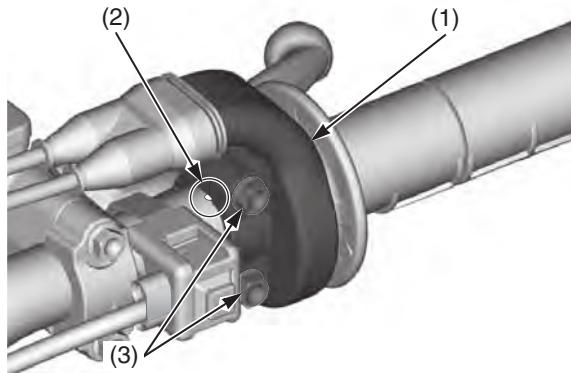

(1) throttle housing
(2) paint mark
(3) housing bolts

2. Check for smooth rotation of the throttle (4) from fully open to fully closed in all steering positions. If there is a problem, see your dealer.

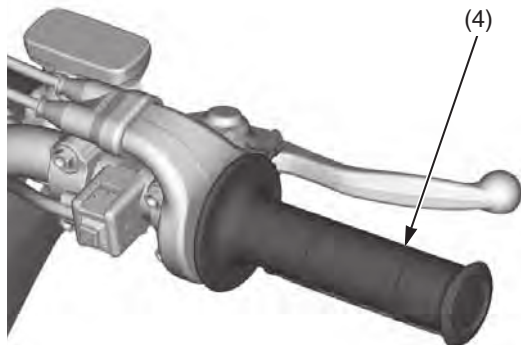

(4) throttle

3. Inspect the condition of the throttle cables from the throttle grip down to the throttle body. If the cable is kinked or chafed, have it replaced.
4. Check the cables for tension or stress in all steering positions.
5. Lubricate the cables with a commercially available cable lubricant.

Throttle Cable Lubrication

Check for smooth rotation of the throttle. If necessary, apply multi-purpose grease to sliding surface of the throttle cable ends.

1. Slide the dust cover (1).
2. Remove the throttle housing bolts (2).
3. Remove the throttle housing (3) from the throttle pipe (4).
4. Thoroughly lubricate the throttle cable ends (5) with multi-purpose grease.

5. Install the throttle housing to the throttle pipe. Check that the throttle assembly is positioned properly (the end of the throttle housing is aligned with the paint mark (6) on the handlebar) and tighten the throttle housing bolts to the specified torque:
7 lbf-ft (10 N·m, 1.0 kgf·m)

NOTICE

Align the lugs (7) of the wire guide with the grooves (8) of the throttle housing.

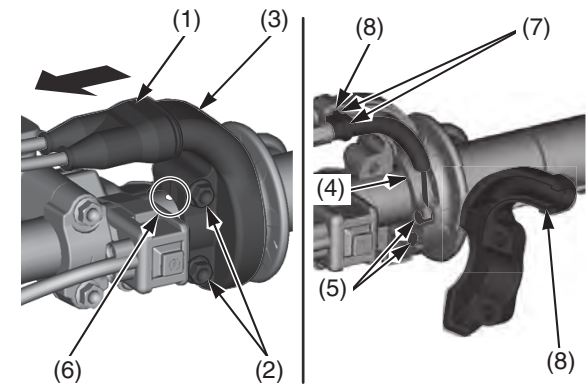

(1) dust cover
(2) housing bolts
(3) throttle housing
(4) throttle pipe
(5) throttle cable ends
(6) paint mark
(7) lugs
(8) grooves

6. Install the dust cover reverse order.

If the throttle operation is not smooth, replace the throttle cable.

Be sure the throttle returns freely from fully open to fully closed automatically, in all steering positions.