

Adding Front Brake Fluid

NOTICE

Spilled brake fluid will severely damage painted surfaces. It is also harmful to some rubber parts. Be careful whenever you remove the reservoir cap; make sure the reservoir is horizontal first.

- Always use fresh DOT 4 brake fluid from a sealed container when servicing the system. Do not mix different types of fluid, they may not be compatible.
 - The recommended brake fluid is Honda DOT 4 Brake Fluid or an equivalent.
1. Remove the front brake reservoir cap screws (1), reservoir cap (2) and diaphragm (3).
 2. Fill the reservoir with DOT 4 brake fluid to the upper level mark (4). Do not overfill.
 3. Install the diaphragm and reservoir cap.
 4. Tighten the front brake reservoir cap screws to the specified torque:
0.7 lbf·ft (1.0 N·m, 0.1 kgf·m)

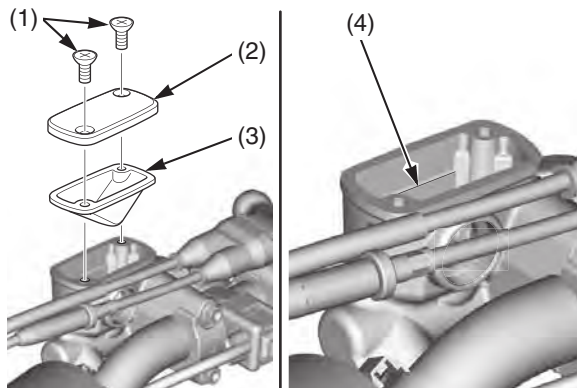

- (1) front brake reservoir cap screws
- (2) reservoir cap
- (3) diaphragm
- (4) upper level mark

Adding Rear Brake Fluid

NOTICE

Spilled brake fluid will severely damage painted surfaces. It is also harmful to some rubber parts. Be careful whenever you remove the reservoir cap; make sure the reservoir is horizontal first.

- Always use fresh DOT 4 brake fluid from a sealed container when servicing the system. Do not mix different types of fluid, they may not be compatible.
 - The recommended brake fluid is Honda DOT 4 Brake Fluid or an equivalent.
1. Remove the rear brake reservoir cap bolts (1), reservoir cap (2), set plate (3) and diaphragm (4).
 2. Fill the reservoir with DOT 4 brake fluid to the upper level mark (5). Do not overfill.

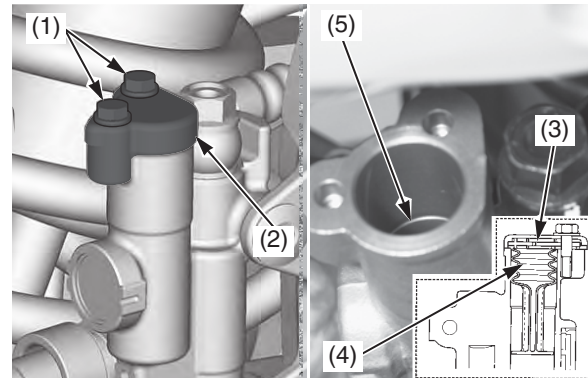

- (1) rear brake reservoir cap bolts
- (2) reservoir cap
- (3) set plate
- (4) diaphragm
- (5) upper level mark

3. Install the diaphragm, set plate and reservoir cap.
4. Tighten the rear brake reservoir cap bolts to the specified torque:
0.7 lbf·ft (1.0 N·m, 0.1 kgf·m)