

Subframe

12. Connect the turn signal light connectors (35). Connect the license light/taillight/brake light connectors (36). Set the connector covers (37) to the rear fender stays (38). Secure the wire harness (33) with the wire harness band (39).

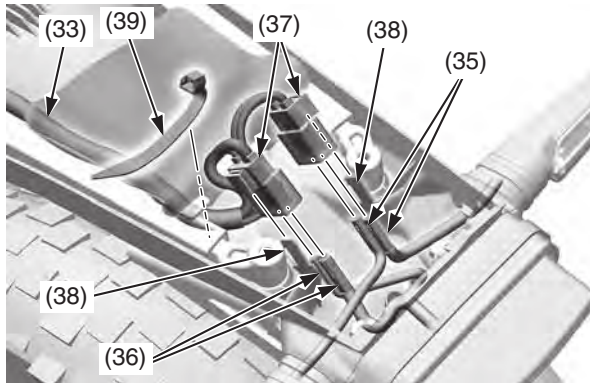

- (33) wire harness
- (35) turn signal connectors
- (36) license light/taillight/brake light connectors
- (37) connector covers
- (38) rear fender stays
- (39) wire harness band

13. Install the rear fender (40), then tighten the rear fender mounting screws (41) to the specified torque:
1.1 lbf-ft (1.5 N-m, 0.2 kgf-m)

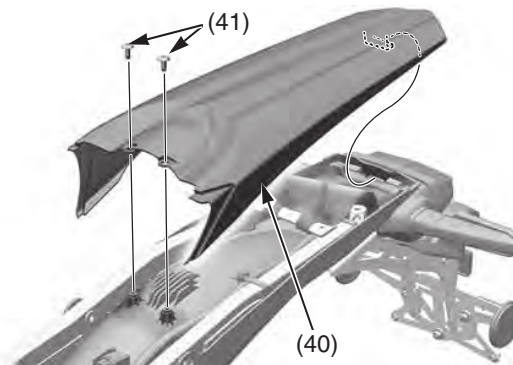

- (40) rear fender
- (41) screws

14. Route the negative (-) battery cable (42) properly, secure it with negative (-) battery cable bands (43).

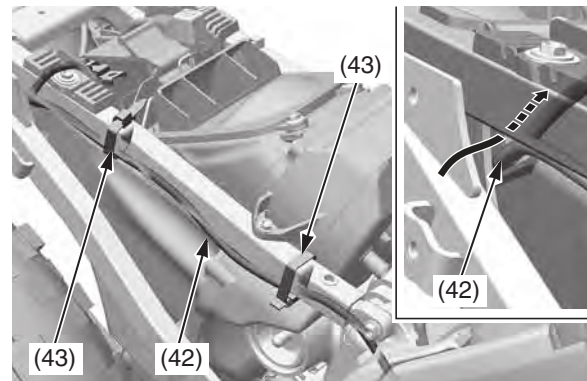

- (42) negative (-) battery cable
- (43) cable bands

15. Connect the crankcase breather tube (43) and air injection air tube (44) to the air cleaner housing (1). Connect the IAT sensor connector (45).

Tighten the air cleaner connecting tube clamp screw (46) so the clamp ends is 0.30 ± 0.06 in (7.5 ± 1.5 mm).

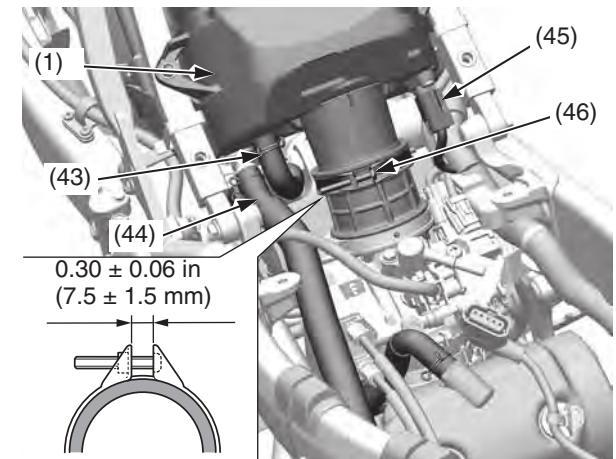

- (1) air cleaner housing
- (43) crankcase breather tube
- (44) air injection air tube
- (45) IAT sensor connector
- (46) connecting tube band screw