

Fuel Tank

14. Check for interference between the frame and tank, and adjust the cushion rubbers (23) on the both sides of the frame if necessary.

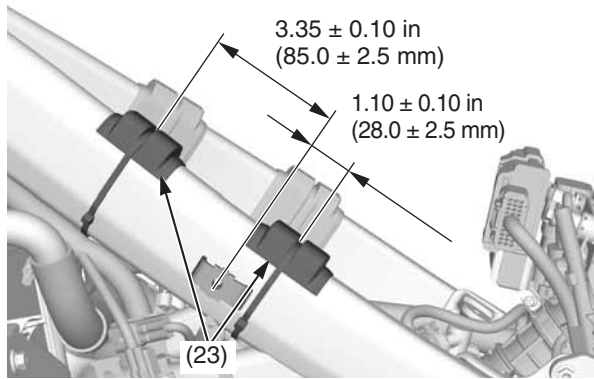

(23) cushion rubbers

NOTICE

Do not ride your motorcycle in state which the cushion rubbers have been removed. It may cause the fuel tank cracking.

Installation

1. Make sure the rubber cover (1) is onto the fuel joint (2) of the fuel pump as shown.

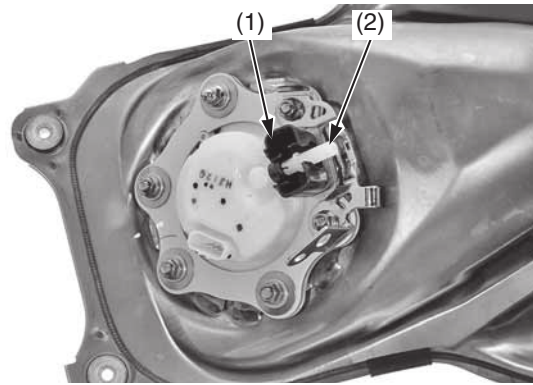

(1) rubber cover
(2) fuel joint

2. Be sure that the slide retainer (3) is completely pulled up before connecting the quick connect fitting.
- Do not bend or twist the fuel feed hose.
 - Do not reuse the kinked or damaged fuel hose.
 - Do not use gloves or a shop towel while installing the quick connect fitting.

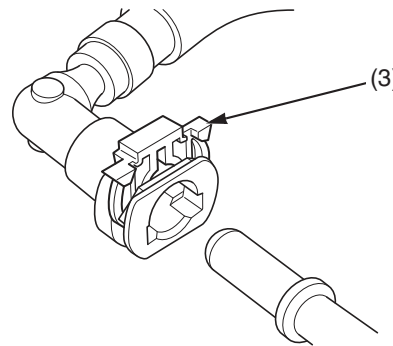

(3) slide retainer

3. Place the fuel tank (4) onto the frame.
4. Connect the quick connect fitting to the fuel joint (2) until you hear the “click” while holding the connector housing (5). If it is hard to connect, put a small amount of engine oil on the pipe end of the fuel joint.

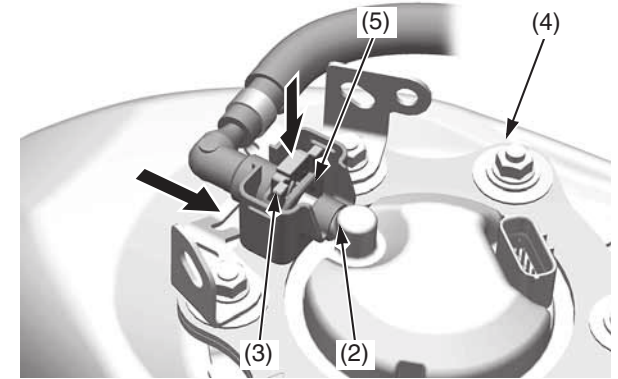

(2) fuel joint
(3) slide retainer
(4) fuel tank
(5) connector housing

5. Make sure the connection is secure and that the slide retainer is firmly locked into place; check visually and by pulling the connector housing.
6. Install the fuel quick connect fitting cover (6). Be sure the rubber cover (1) is properly installed between the fuel quick connect fitting cover and fuel pump.

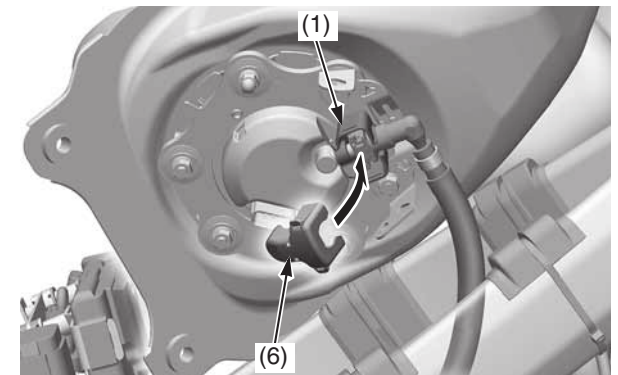

(1) rubber cover
(6) fuel quick connect fitting cover