

Subframe

11. Remove the positive (+) battery cable bands (21), then release the positive (+) battery cable (22) from the subframe (13).

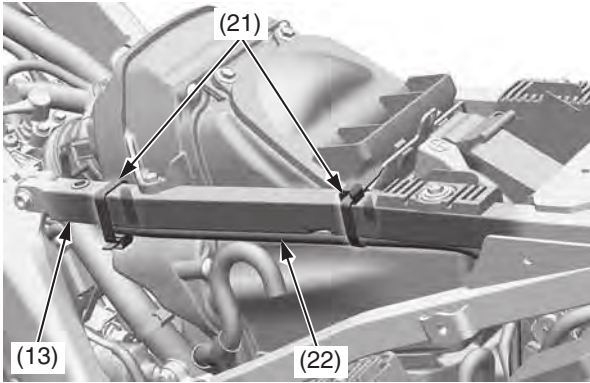

(13) sub frame
(21) cable bands
(22) positive (+) battery cable

12. Disconnect the taillight connectors (23).
Remove the fuse box assembly mounting bolt/washer (24).
Remove the regulator/rectifier mounting bolts (25).

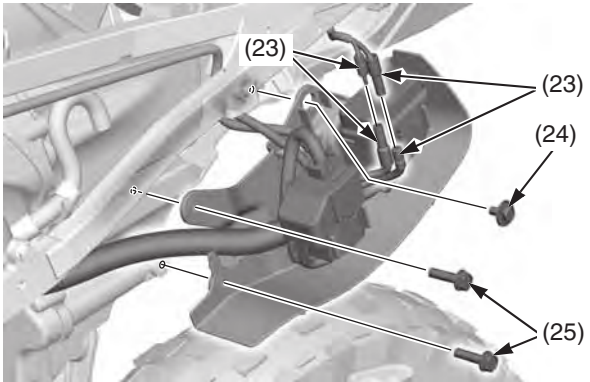

(23) taillight connectors
(24) fuse box assembly mounting bolt/washer
(25) regulator/rectifier mounting bolts

13. Remove the rear fender mounting bolt (26).
Remove the rear fender (27) to the rearward being careful not to damage the taillight wire harness.

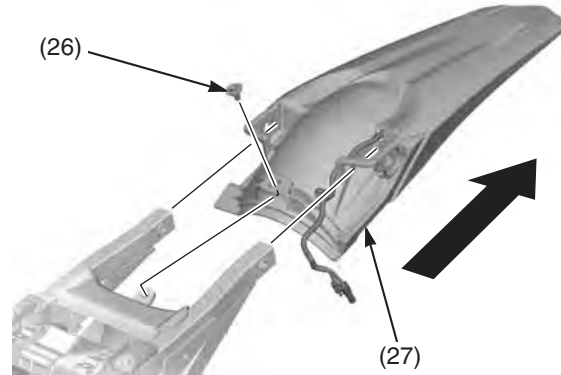

(26) rear fender mounting bolt
(27) rear fender

14. Remove the flange nut (28) and release the wire harness guide (29) from the subframe.
Release the canister air tube (30) from the air cleaner housing boss (31).

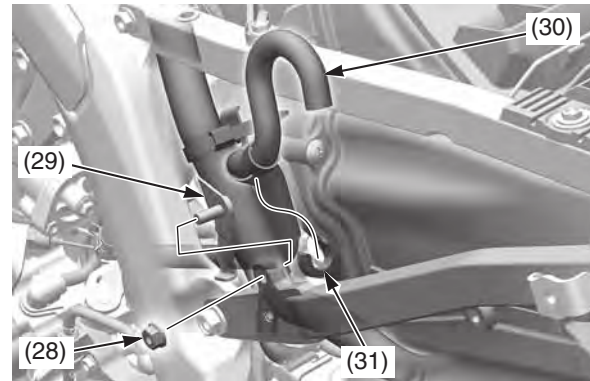

(28) flange nut
(29) harness guide
(30) canister air tube
(31) boss

15. Remove the air cleaner housing mounting bolts A (32), air cleaner housing mounting bolts B (33) and collars (34).

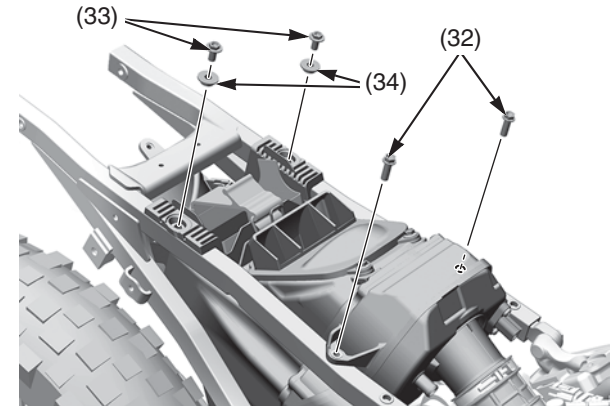

(32) air cleaner housing mounting bolts A
(33) air cleaner housing mounting bolts B
(34) collars

16. Remove the subframe upper mounting bolts (35) and lower mounting bolts (36).
Remove the subframe (13) to the rearward being careful not to damage the wire harness.

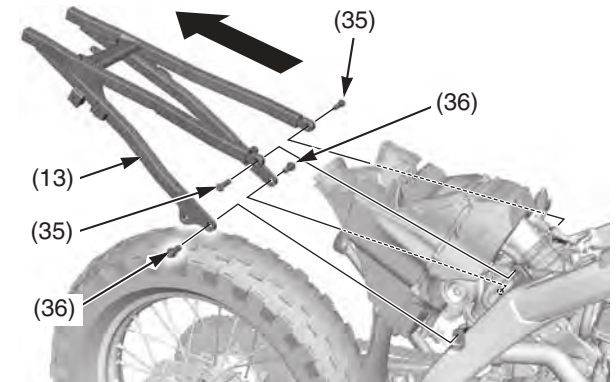

(13) sub frame
(35) upper mounting bolts
(36) lower mounting bolts