

- Tighten the fork center bolt lock nut (2) fully and measure the thread length (A) as shown. Standard: 0.43 – 0.47 in (11 – 12 mm)
Wipe the oil completely off the fork damper.

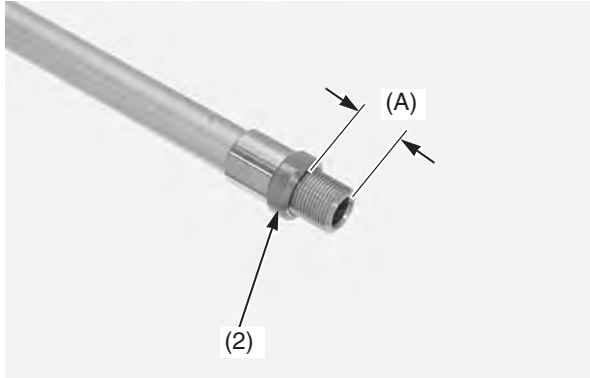

(2) fork center bolt lock nut (A) thread length

- Apply recommended fork oil to the slider bushing (3).
Install the seat stopper (4), back-up ring (5) and spring seat collar (6) to the fork damper (7).
Make sure the black side of the back-up ring is seated on the seat stopper side.

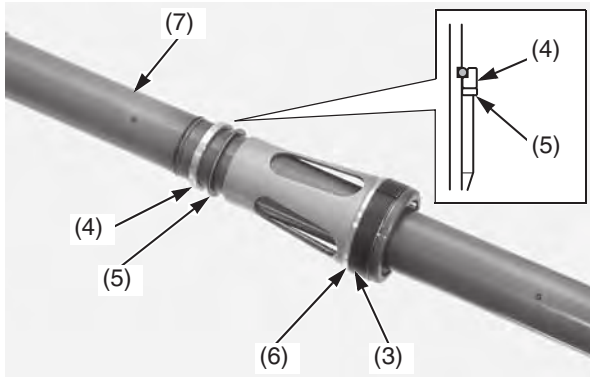

(3) slider bushing (4) seat stopper (5) back-up ring (6) spring seat collar (7) fork damper

- Blow out the oil completely off the fork spring (8).
Put the fork spring on the fork damper assembly (9).
Install the spring/fork damper assembly into the fork assembly (1).

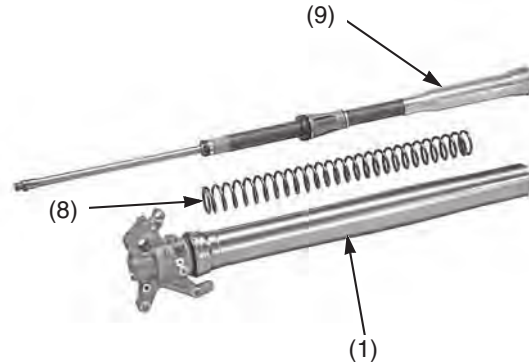

(1) fork assembly (8) fork spring (9) fork damper assembly

- Temporarily tighten the fork damper assembly (9) to the outer tube (10) using the lock nut wrench (11).

- Lock nut wrench 07WMA-KZ30100

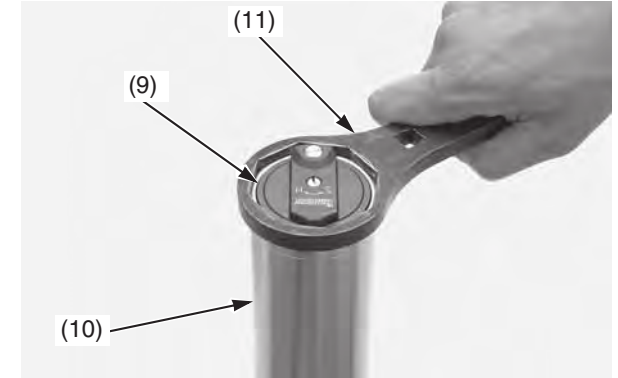

(9) fork damper assembly (10) outer tube (11) lock nut wrench

- Place the lower end (axle holder) (12) of the slider in a vise with a piece of wood or soft jaws to avoid damage.

NOTICE

Over-tightening the vise can damage the axle holder.

- Push the outer tube until the fork center bolt lock nut (2) is fully exposed and install the piston base (13) or mechanic's stopper tool between the axle holder (12) and fork center bolt lock nut.

- Measure the thread length again. Standard: 0.43 – 0.47 in (11 – 12 mm)
- Piston base 07958-2500001

(cont'd)