

Checking the Final Drive Oil

1. Hold the vehicle upright on firm level ground.
2. Remove the oil fill hole cap and O-ring.
3. Check the oil level. It should be flush with the lower edge of the oil fill hole.

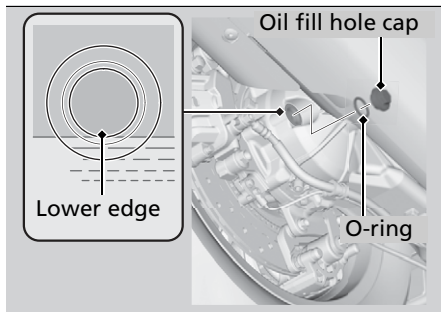

Adding Final Drive Oil

If the final drive oil level is low, check for oil leaks. Add the recommended final drive oil (➤ P. 149) until it reaches the lower edge of the opening.

1. Pour the final drive oil into the oil fill hole until it reaches the lower edge of the opening.
 - ▶ Do not over fill above the lower edge of oil fill hole.
 - ▶ Make sure no foreign objects enter the oil fill hole.
 - ▶ Wipe up any spills immediately.
2. Install a new O-ring onto the oil fill hole cap. Tighten the oil fill hole cap.

Torque: 5.9 lbf-ft (8 N·m, 0.8 kgf·m)

Changing Final Drive Oil

1. Hold the vehicle upright on firm level ground.
2. Place a drain pan under the drain bolt.
3. Remove the oil fill hole cap, O-ring, drain bolt, and sealing washer to drain the oil.

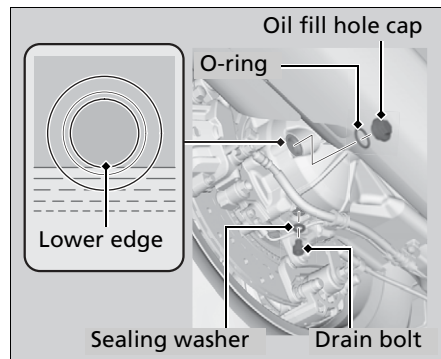

4. Install a new sealing washer onto the drain bolt. Tighten the drain bolt.

Torque: 9 lbf-ft (12 N·m, 1.2 kgf·m)

5. Fill the final gear with the recommended oil. ➤ P. 149

Required oil: 4.7 US oz (140 cm³)

6. Check the oil level. It should be flush with the lower edge of the oil fill hole.
7. Install a new O-ring onto the oil fill hole cap. Tighten the oil fill hole cap.

Torque: 5.9 lbf-ft (8 N·m, 0.8 kgf·m)

8. Check that there are no oil leaks.