

## Frame servicing

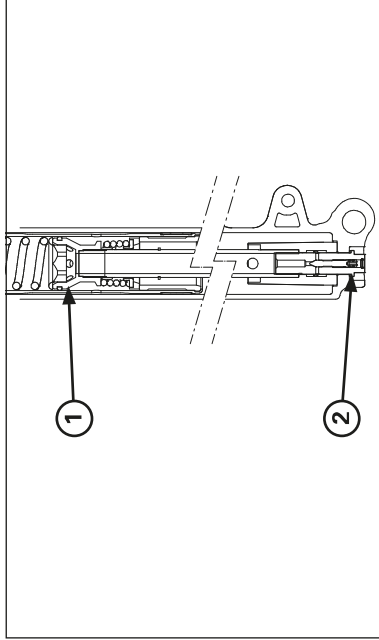

- (1) CILINDER ASSY
- (2) CENTER BOLT

Hold the axle holder in a vise protected with a piece of wood or soft jaws to avoid damage.  
Do not overtighten the vise.

Install the center bolt with a new sealing washer.  
Tighten the center bolt to the specified torque.

**Torque: 23.5-25.5 N•m (2.4-2.6 kgf•m)**

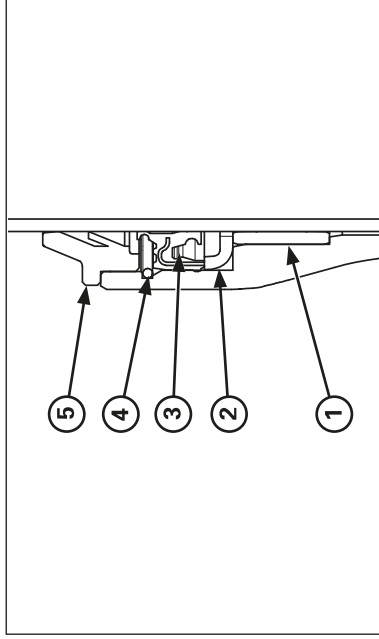

- (1) GUIDE BUSHING
- (2) BACK-UP RING
- (3) OIL SEAL
- (4) STOP RING
- (5) DUST SEAL

Install the following parts onto the fork tube using the same procedure as the right fork (page 5-6):

- Fork tube bushing
- Guide bushing
- Back-up ring

Using the special tool, drive the guide bushing and back-up ring until the stop ring groove is fully stuck in the fork slider base.

Install the oil seal (spring up) in the fork slider. Drive the oil seal using the special tool, performing a constant pressure until stops in back-up ring.

**Tool:**

**Fork seal driver**

**07947-4630100**

Install the stop ring into the slider groove securely.  
Install the dust seal.

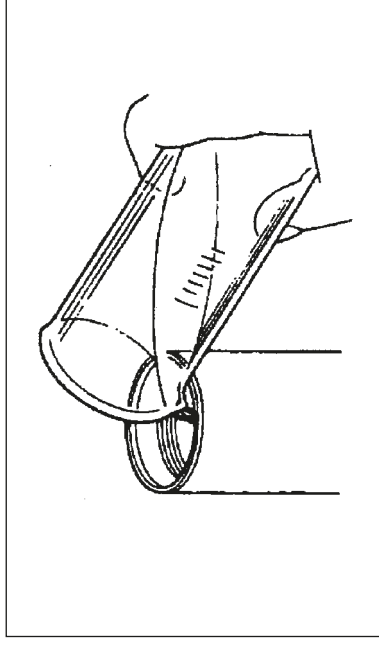

Pour half the required amount of recommended fork fluid in the fork tube.

**Specified fork fluid:**  
**OJ Racing Special Fork Oil Type 01 (SAE 5W) or equivalent**

Pump the fork tube slowly 8-10 times.  
Pour additional fluid to the specified capacity.

**Oil level:** 125 mm (4.9 in)  
**Oil capacity (orientative):** 285 cc  
(9.6 US oz)  
(10.0 Imp oz)

**NOTICE**

*Totally extended fork may cause oil leakage.*