

(1) BEARINGS
(2) GROOVE

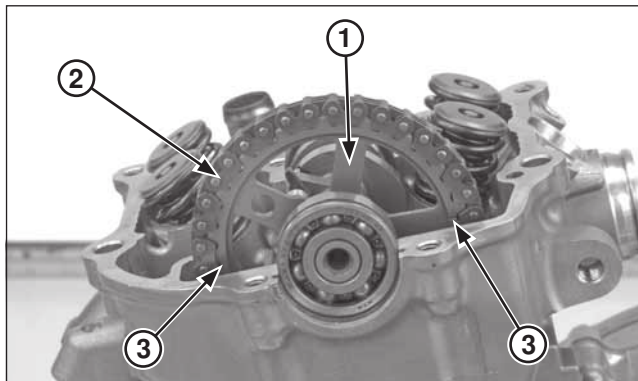

(1) CAM SPROCKET
(2) CAM CHAIN
(3) INDEX MARKS

Apply molybdenum oil solution to the camshaft cam surface.
Install the bearings both ends of the camshaft.
Install the left camshaft bearing with its groove side facing out.

Install the cam chain onto the cam sprocket, then install the camshaft onto the cylinder head while aligning the index marks on the cam sprocket with the upper surface of the cylinder head.

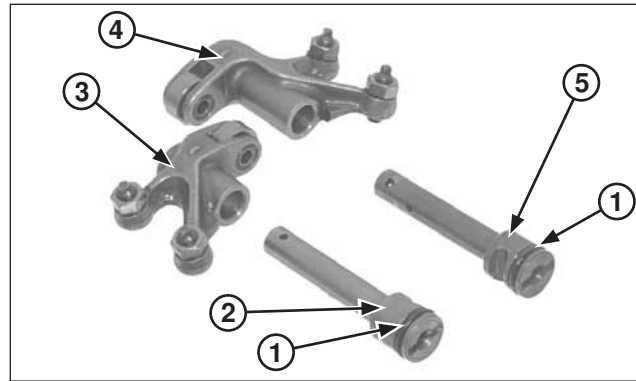

(1) NEW O-RINGS
(2) INTAKE ROCKER ARM SHAFT
(3) INTAKE ROCKER ARM
(4) EXHAUST ROCKER ARM
(5) EXHAUST ROCKER ARM SHAFT

Cylinder Head Cover Assembly

Apply molybdenum oil solution to the rocker arm I.D. and rocker arm shaft sliding surface.
Install new O-ring to each rocker arm shaft groove.

Place the intake rocker and exhaust rocker arm into the cylinder head cover.
The intake rocker arm is identified with groove on the end of the shaft.

Install the intake and exhaust rocker arm shafts with their cut-out facing in and the shaft end oil hole facing up as shown.

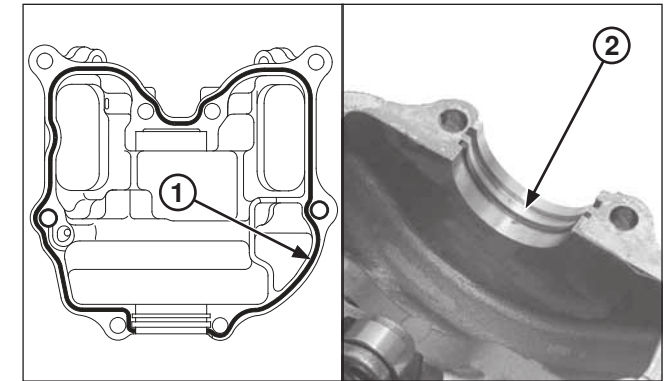

(1) APPLY SEALANT
(2) BEARING RETAINER

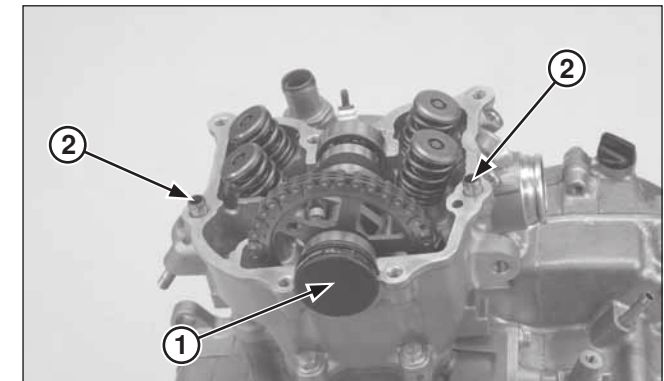

(1) CAMSHAFT END CAP
(2) DOWEL PINS

Cylinder Head Cover Installation

Apply sealant to the mating surface of the cylinder head cover.
Install the camshaft bearing retainer into the cylinder head cover inner groove.

Install the camshaft end cap.