

## Frame servicing

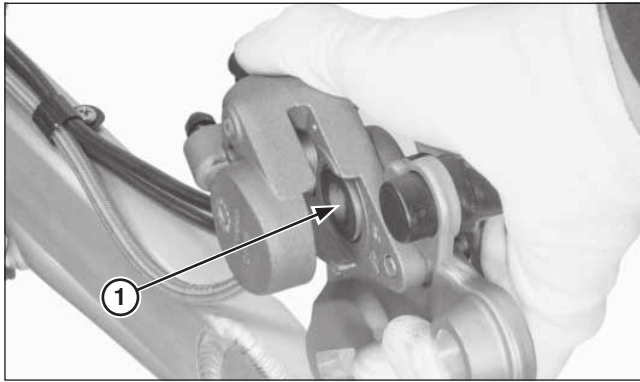

(1) CALIPER PISTON

### Inspection

Clean the inside of the caliper.  
Check the oil leakage from the caliper cylinder.

If any part of the caliper is damaged, replace the caliper as an assembly.

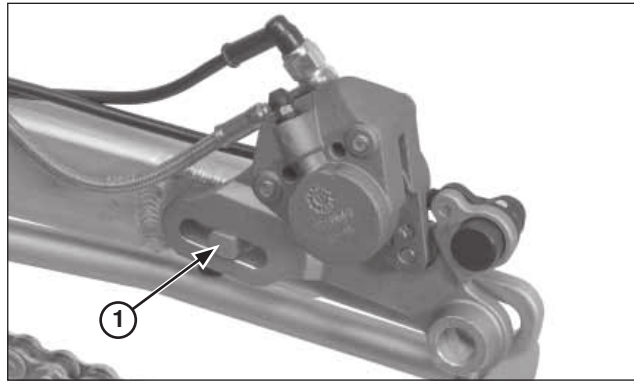

(1) SWINGARM BOSS

### Installation

Install the brake caliper onto the swingarm rail.  
Connect the brake hose eyelet joint with two new sealing washers.

Install the rear wheel (page 4-16).

Tighten the oil bolt to the specified torque.

**Torque: 26 N·m (2.7 kgf·m, 20 lbf·ft)**

Bleed the air in the rear brake system.

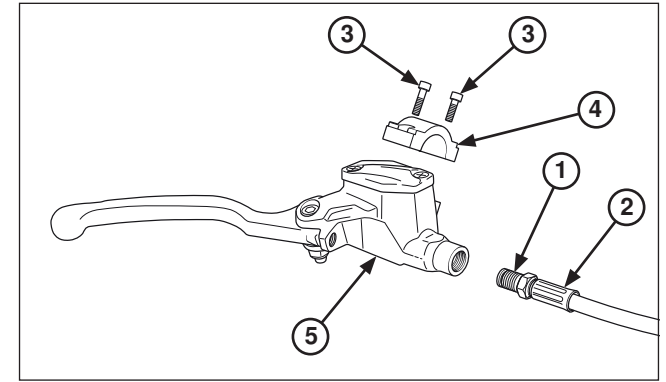

- (1) OIL BOLT
- (2) BRAKE HOSE
- (3) BOLT
- (4) HOLDER
- (5) MASTER CYLINDER

### Front master cylinder

#### Removal/Installation

#### NOTICE

- *Avoid spilling brake fluid on painted, plastic or rubber parts. Place a shop rag over these parts whenever the system is serviced.*
- *When removing the brake hose bolt, cover the end of the hoses to prevent contamination. Secure the hoses to prevent fluid from leaking out.*
- 

Drain the brake fluid from the hydraulic system into a suitable container.

Remove the following:

- Brake lever
- Brake hose bolt
- Master cylinder holder bolt and holder
- Master cylinder