

# Safety Labels

**BRAKING INFORMATION**

With four-wheel drive, operating any brake control causes braking at both the front and rear wheels. For detailed braking information, refer to the Owner's Manual.

**WARNING**

**UNDER 16**

Operating this ATV if you are under the age of 16 increases your chance of severe injury or death.

**NEVER** operate this ATV if you are under age 16.

**WARNING**

Overloading this ATV or carrying cargo improperly can change handling, stability and braking performance and can lead to an accident.

Never exceed the maximum rear cargo limit (combined weight on the rear rack and in the storage area) of: 133 lbs (60 kg).

Refer to instructions in the Owner's Manual.

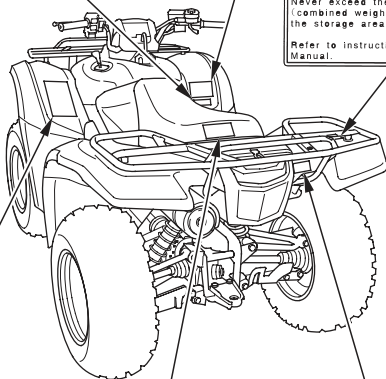

**WARNING**

Improper ATV use can result in SEVERE INJURY or DEATH.

**NEVER** operate:

- without proper training or instruction
- at speeds too fast for your skills or the conditions
- on public roads - a collision can occur with another vehicle
- with a passenger - passengers affect balance and steering and increase risk of losing control

**ALWAYS:**

- use proper riding techniques to avoid vehicle overturns on hills and rough terrain and in turns
- avoid paved surfaces - pavement may seriously affect handling and control

LOCATE AND READ OWNER'S MANUAL.  
FOLLOW ALL INSTRUCTIONS AND WARNINGS.

**WARNING**

**NEVER** ride as a passenger. Passengers can cause a loss of control, resulting in SEVERE INJURY or DEATH.

**WARNING**

Towing an improperly loaded trailer can cause loss of control.

- Read towing instructions in owner's manual
- Tow weight limit : **850lbs. (385kg)**
- Tongue weight : **30lbs. ( 14kg)**