

Front Suspension Damping

Refer to *Safety Precautions* on page 73 .

Rebound Damping RIGHT FRONT

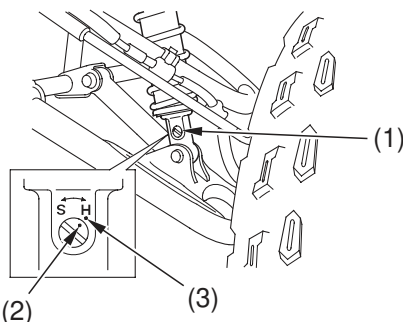

- (1) rebound damping adjuster (3) reference punch mark
(2) punch mark

To adjust to the standard position:

1. Turn the rebound damping adjuster (1) clockwise until it will no longer turn (lightly seats). This is the full hard setting.
2. Turn the adjuster counterclockwise approximately 1 turns so that the punch mark (2) on the adjuster aligns with the reference punch mark (3). This is the standard position.
3. Make sure that both shock absorbers are adjusted to the same position.

To Reduce Rebound Damping (SOFT):

For a light load and smooth road conditions, turn the adjuster counterclockwise toward SOFT (S).

To Increase Rebound Damping (HARD):

For a firmer ride and rough road conditions, turn the adjuster clockwise toward HARD (H).