

Fig. 6-11 ① Float valve seat ② Float valve

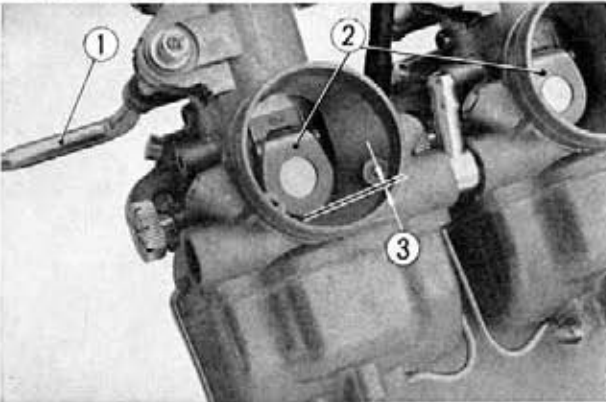

Fig. 6-12 ① Choke lever ② Choke valve
③ Clearance between choke valve and body

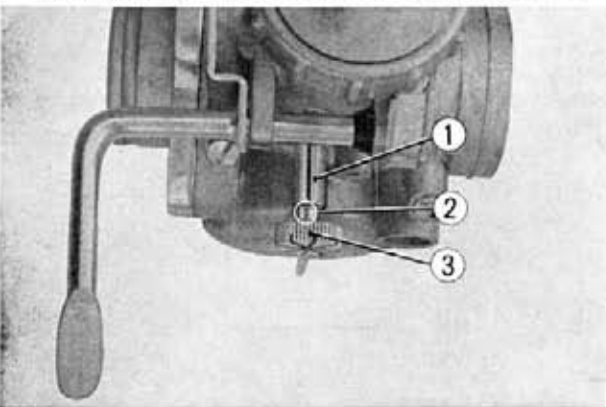

Fig. 6-13 ① Index mark ③ Throttle stop screw
② "T" mark

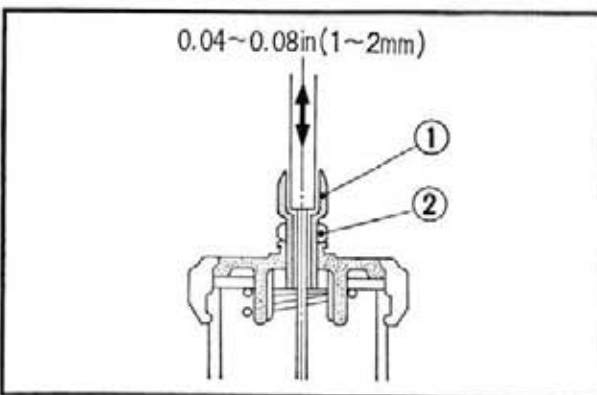

Fig. 6-14 ① Cable adjuster
② Cable adjuster lock nut

2. When either the float valve or valve seat requires replacement, they should be replaced in set. (Fig. 6-11)
3. Install the respective carburetor on the stay plate with two mounting screws and connect the choke rod to the carburetor; make sure that the action of the choke lever is smooth.
4. Install the carburetor assembly on the cylinder head.
5. Assemble the throttle valves and cables on the carburetors and actuate the throttle grip to assure smooth movement of the cable.

6. Carburetor adjustment

Before attempting carburetor adjustment, make sure that the following adjustments have been performed properly.

- a. Contact breaker point gap
- b. Ignition timing
- c. Valve tappet clearance
- d. Spark plug gap
- e. Crankcase oil level

(1) Preliminary adjustment

- a. To make easy of access to the throttle screws on all carburetors, the fuel tank should be removed.
- b. To check the operation of the choke valves remove the air cleaner upper and lower cases. Observe the choke valves from the rear side of the carburetors whether all valves are fully closed or not, when the choke lever is operated.

If there is a clearance greater than **0.02 in. (0.5 mm)** between the choke valve and body, adjust the clearance by lengthening or shortening the choke lever adjusting rod connected to the annex carburetor. (Fig. 6-12)

- c. Adjust the throttle stop screw to align the "T" mark to the index mark stamped on the carburetor body. Perform adjustments on all carburetors. (Fig. 6-13)
- d. Loosen the throttle cable adjuster lock nut and turn the cable adjuster to either directions to obtain the free play of the throttle cable outer within the range of **0.04~0.08 in (1~2mm)**. After tightening the lock nut check the movement of the outer cable.

The four throttle cables should all be adjusted uniformly. (Fig. 6-14)