

## DRIVE CHAIN CONNECTOR AND DISCONNECTOR OPERATION

On the models CB 750, it is necessary to cut the endless chains. To cut the chains, proceed as follows:

### A. Disconnection of Drive Chain

1. Position chain link pin to be cut on chain holder in place as shown in Fig. 20-35. Screw in pressure bolt until pressure holder holds chain in position. Back off adjuster bolt so that it does not interfere with chain.
2. By use of handlebar, screw in pressure bolt B until before joint pin is just pushed off joint plate.
3. Position adjacent chain link pin on chain holder and repeat step 1 and 2. screw in pressure bolt B until joint pin is completely pushed off joint plate.
4. Reposition original chain link pin on chain holder and disconnect chain by pushing off joint pin in the same way as in step 3.

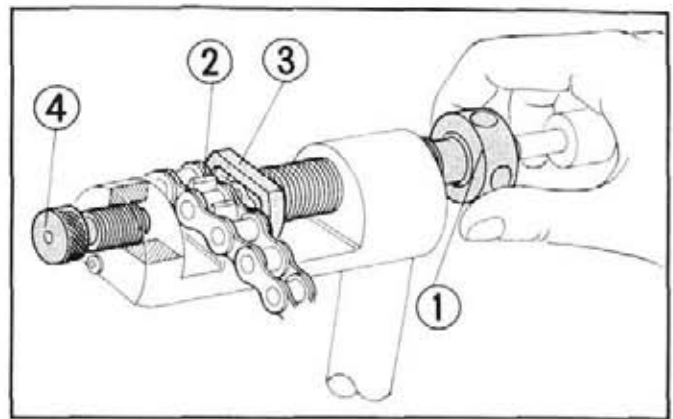

Fig. 20-35 ① Pressure bolt ③ Pressure holder  
② Chain holder ④ Adjuster bolt

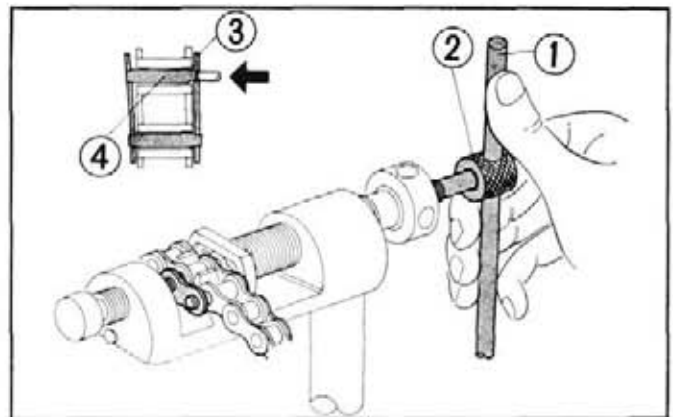

Fig. 20-36 ① Handlebar ③ Joint plate  
② Pressure bolt B ④ Joint pin

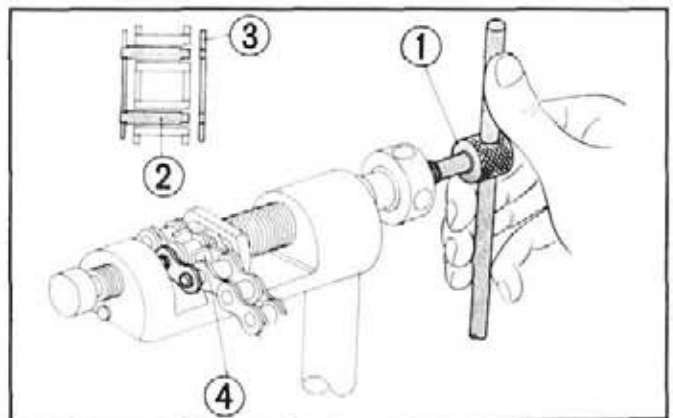

Fig. 20-37 ① Pressure bolt B ③ Joint plate  
② Joint pin ④ Chain holder

### B. Press-in Connection of Drive Chain

Newly improved chain joints and plates are of a pressfitted type. Only press-fitted type chain joint and plate require this procedure.

1. Join new drive chain by inserting joint pin (1) from side toward enter of motorcycle.

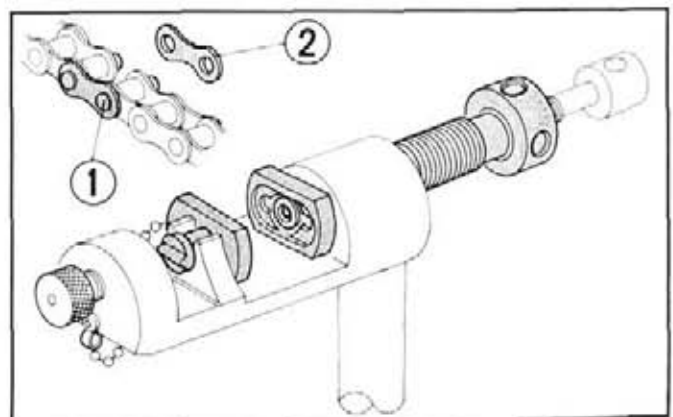

Fig. 20-38 ① Joint pin ② Chain link