

Turn the cam chain tensioner lifter shaft fully and secure it using the mechanic's tensioner stopper tool (page 8-6).

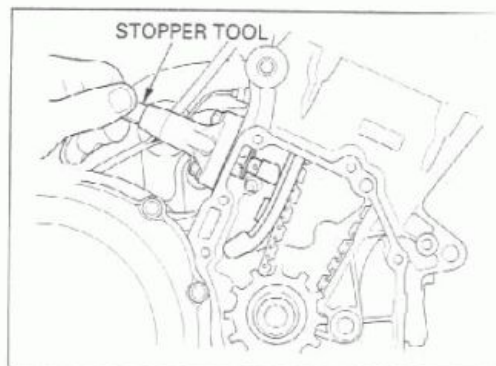

Remove the timing hole cap and O-ring.

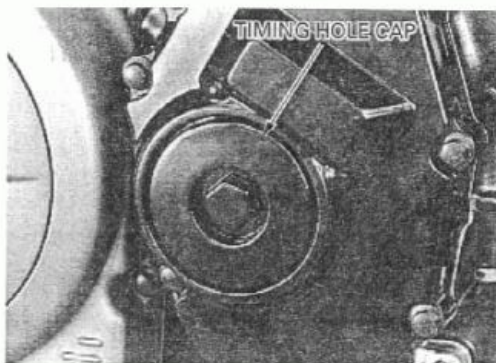

Turn the crankshaft clockwise so the "T" mark on the ignition pulse generator rotor aligns with the index mark on the ignition pulse generator rotor cover.



The timing marks ("IN" and "EX") on the cam sprockets must be flush with the cylinder head surface and facing outward as shown.

If the timing marks on the cam sprocket face inward, turn the crankshaft clockwise one full turn (360°) and realign the timing marks with the cylinder head surface so they are facing outward.

