

# HYDRAULIC BRAKE

## INSPECTION

Check the caliper cylinder and pistons for scoring, scratches or damage.

Measure the caliper cylinder I.D.

**SERVICE LIMIT:** 27.06 mm (1.065 in)

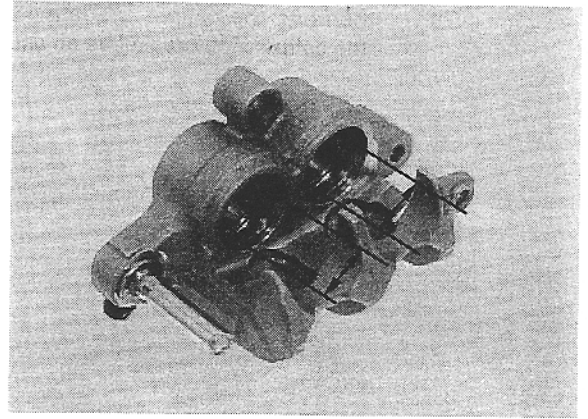

Measure the caliper piston O.D.

**SERVICE LIMIT: ED, DK types:** 26.89 mm (1.059 in)  
**U type:** 26.91 mm (1.059 in)

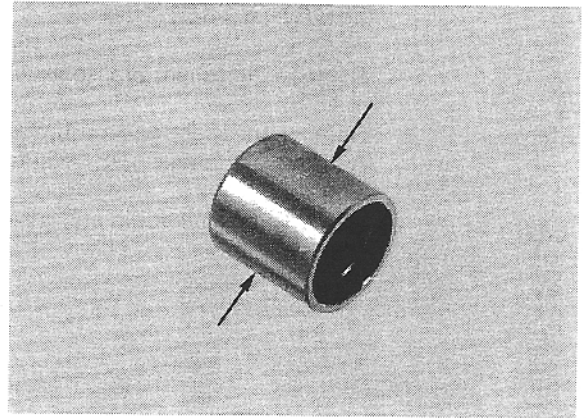

## ASSEMBLY

### NOTE:

Be sure that each part is free from the dust or dirt before reassembly.

Coat the new piston seals and dust seals with clean brake fluid.

Install the new piston seals and dust seals into the groove of the caliper body.

Coat the caliper pistons with clean brake fluid and install them into the caliper cylinder with their open ends facing the pad.

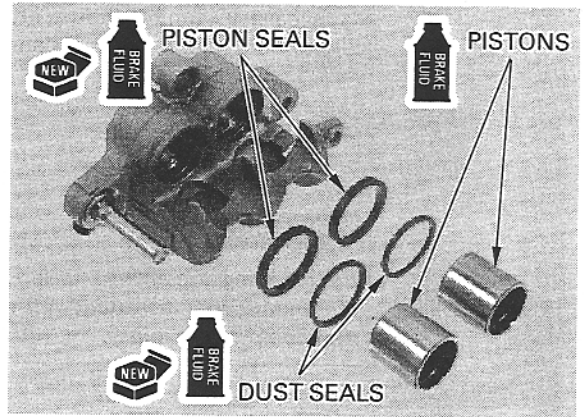

Install the brake pad retainer onto the caliper bracket.

Install the pad spring into the caliper body.

Replace the caliper and bracket pin boots if it is wear, deterioration or damage.

Apply silicone grease to the boot inside then install them.

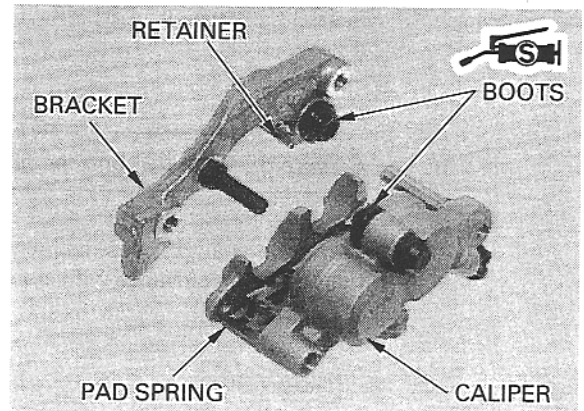

*Note the installation direction of the pad spring.*

*When assembling the caliper and bracket, set the boot into the slide pin groove.*

Assemble the caliper and bracket.